

Extrablame®

Riscaldamento a Pellet



UK

PELLET STOVES USER MANUAL

MADE IN ITALY
design & production

MOIRA SP

004277423 - Rev 001



! ATTENTION



**SURFACES CAN BECOME VERY HOT!
ALWAYS USE PROTECTIVE GLOVES!**

During combustion, thermal energy is released that significantly increases the heat of surfaces, doors, handles, controls, glass, exhaust pipes, and even the front of the appliance. Avoid contact with those elements if not wearing protective clothing (protective gloves included). Make sure children are aware of the danger and keep them away from the stove during operation.

ENGLISH	4
WARNINGS	4
SAFETY	4
ROUTINE MAINTENANCE	5
INSTALLATION	6
MINIMUM DISTANCES	6
HERMETIC INSTALLATION	8
COMBUSTION AIR	8
FUMES EXHAUST SYSTEM	8
DETAILS OF MOIRA SP	9
STOVE POSITIONING	10
NOTE FOR CORRECT FUNCTIONING	10
FUSE	10
PELLETS AND LOADING	11
PELLET HOPPER - PRESSURISED CLOSURE	11
RADIO/EMERGENCY CARD	12
HANDHELD	13
CONFIGURATION	13
HANDHELD ROOM PROBE CALIBRATION	13
BATTERY TYPE AND REPLACEMENT	13
HANDHELD FEATURES	14
DISPLAY	15
GENERAL MENU	16
BASIC INSTRUCTIONS	16
FIRST START-UP SETTINGS	17
DATE-TIME	17
LANGUAGE	17
SET DEGREES	17
FUNCTIONING AND LOGIC	18
FRONT AIR	19
EASY SETUP	19
CHRONO	20
ENABLING	20
PRG 1-4	20
SETTINGS	23
DISPLAY	23
STAND-BY	23
FUNCTIONING WITH SUPPLEMENTARY THERMOSTAT (OPTIONAL)	23
DELTA T	24
RESET	24
ADDITIONAL FUNCTIONS	24
FIRST LOAD	24
INSTALLATION OF SUPPLEMENTARY THERMOSTAT (OPTIONAL)	24
DELAYED SWITCH-OFF	24
CLEANING AND MAINTENANCE	25
MAINTENANCE	25
PERIODIC CLEANING UNDER USER RESPONSIBILITY	25
ROUTINE MAINTENANCE PERFORMED BY QUALIFIED TECHNICIANS	27
DECOMMISSIONING (END OF SEASON)	27
READINGS	30
ALARMS	30
GUARANTEE TERMS	31

We thank you for having chosen our company; our product is a great heating solution developed from the most advanced technology with top quality machining and modern design, aimed at making you enjoy the fantastic sensation that the heat of a flame gives, in complete safety.

WARNINGS

This instructions manual is an integral part of the product: make sure that it always accompanies the appliance, even if transferred to another owner or user, or if transferred to another place. If it is damaged or lost, request another copy from the area technician. This product is intended for the use for which it has been expressly designed. The manufacturer is exempt from any liability, contractual and extracontractual, for injury/damage caused to persons/animals and objects, due to installation, adjustment and maintenance errors and improper use.

Installation must be performed by qualified staff, which assumes complete responsibility for the definitive installation and consequent good functioning of the product installed. One must also bear in mind all laws and national, regional, provincial and town council Standards present in the country in which the appliance has been installed, as well as the instructions contained in this manual.

The Manufacturer cannot be held responsible for the failure to comply with such precautions.

After removing the packaging, ensure that the content is intact and complete. Otherwise, contact the dealer where the appliance was purchased.

All electric components that make up the product must be replaced with original spare parts exclusively by an authorised after-sales centre, thus guaranteeing correct functioning.

SAFETY

- ◆ THE APPLIANCE MAY BE USED BY CHILDREN 8 YEARS OF AGE OR OLDER AND INDIVIDUALS WITH REDUCED PHYSICAL, SENSORY, OR MENTAL CAPACITIES OR WITHOUT EXPERIENCE OR THE NECESSARY KNOWLEDGE, PROVIDED THAT THEY ARE SUPERVISED OR HAVE RECEIVED INSTRUCTIONS ON SAFE USE OF THE APPLIANCE AND THAT THEY UNDERSTAND THE INHERENT DANGERS.
- ◆ THE GENERATOR MUST NOT BE USED BY PERSONS (INCLUDING CHILDREN) WITH REDUCED PHYSICAL, SENSORY AND MENTAL CAPACITIES OR WHO ARE UNSKILLED PERSONS, UNLESS THEY ARE SUPERVISED AND TRAINED REGARDING USE OF THE APPLIANCE BY A PERSON RESPONSIBLE FOR THEIR SAFETY.
- ◆ THE CLEANING AND MAINTENANCE REQUIRED BY THE USER MUST NOT BE PERFORMED BY CHILDREN WITHOUT SUPERVISION.
- ◆ CHILDREN MUST BE CHECKED TO ENSURE THAT THEY DO NOT PLAY WITH THE APPLIANCE.
- ◆ DO NOT TOUCH THE GENERATOR WHEN YOU ARE BAREFOOT OR WHEN PARTS OF THE BODY ARE WET OR DAMP.
- ◆ THE SAFETY AND ADJUSTMENT DEVICES MUST NOT BE MODIFIED WITHOUT THE AUTHORISATION OR INDICATIONS OF THE MANUFACTURER.
- ◆ DO NOT PULL, REMOVE, TWIST THE ELECTRICAL CABLES COMING OUT OF THE PRODUCT EVEN IF IT IS DISCONNECTED FROM THE MAINS.
- ◆ IT IS ADVISED TO POSITION THE POWER SUPPLY CABLE SO THAT IT DOES NOT COME INTO CONTACT WITH HOT PARTS OF THE APPLIANCE.
- ◆ THE POWER SUPPLY PLUG MUST BE ACCESSIBLE AFTER INSTALLATION.
- ◆ DO NOT CLOSE OR REDUCE THE DIMENSIONS OF THE AIRING VENTS IN THE PLACE OF INSTALLATION. THE AIRING VENTS ARE ESSENTIAL FOR CORRECT COMBUSTION.
- ◆ DO NOT LEAVE THE PACKAGING ELEMENTS WITHIN REACH OF CHILDREN OR UNASSISTED

DISABLED PERSONS.

- ◆ THE HEARTH DOOR MUST ALWAYS BE CLOSED DURING NORMAL FUNCTIONING OF THE PRODUCT.
- ◆ WHEN THE APPLIANCE IS FUNCTIONING AND HOT TO THE TOUCH, ESPECIALLY ALL EXTERNAL SURFACES, ATTENTION MUST BE PAID
- ◆ CHECK FOR THE PRESENCE OF ANY OBSTRUCTIONS BEFORE SWITCHING THE APPLIANCE ON FOLLOWING A PROLONGED PERIOD OF INACTIVITY.
- ◆ THE GENERATOR HAS BEEN DESIGNED TO FUNCTION IN ANY CLIMATIC CONDITION. IN PARTICULARLY ADVERSE CONDITIONS (STRONG WIND, FREEZING) SAFETY SYSTEMS MAY INTERVENE THAT SWITCH THE GENERATOR OFF. IF THIS OCCURS, CONTACT THE TECHNICAL AFTER-SALES SERVICE AND ALWAYS DISABLE THE SAFETY SYSTEMS.
- ◆ IN THE EVENT THE FLUE CATCHES FIRE, USE SUITABLE SYSTEMS FOR SUFFOCATING THE FLAMES OR REQUEST HELP FROM THE FIRE BRIGADE.
- ◆ THIS APPLIANCE MUST NOT BE USED TO BURN WASTE
- ◆ DO NOT USE ANY FLAMMABLE LIQUIDS FOR IGNITION
- ◆ DURING THE FILLING PHASE DO NOT PUT THE BAG OF PELLETS TO INTO CONTACT WITH THE PRODUCT
- ◆ THE MAJOLICAS ARE TOP QUALITY ARTISAN PRODUCTS AND AS SUCH CAN HAVE MICRO-DOTS, CRACKLES AND CHROMATIC IMPERFECTIONS. THESE FEATURES HIGHLIGHT THEIR VALUABLE NATURE. DUE TO THEIR DIFFERENT DILATION COEFFICIENT, THEY PRODUCE CRACKLING, WHICH DEMONSTRATE THEIR EFFECTIVE AUTHENTICITY. TO CLEAN THE MAJOLICAS, IT IS RECOMMENDED TO USE A SOFT, DRY CLOTH. IF A DETERGENT OR LIQUID IS USED, THE LATTER COULD PENETRATE INSIDE THE CRACKLES, HIGHLIGHTING THEM.

ROUTINE MAINTENANCE

Based on Decree 22 January 2008 n°37 art.2, routine maintenance means interventions aimed at reducing degradation due to normal use, as well as dealing with accidental events entailing the need of first interventions, which however do not modify the structure of the system upon which one is intervening or its intended use according to the requirements laid down by the technical standards in force and by the manufacturer's use and maintenance manual.

INSTALLATION

GENERAL

The flue gas exhaust and hydraulic connections must be carried out by qualified personnel who must issue installation conformity documentation compliant with national standards.

The installer must provide the owner or person acting for him, according to the legislation in force, with the declaration of conformity, supplied with:

- 1) the use and maintenance manual of the appliance and of the system components (such as for example, the smoke ducts, chimney, etc.);
- 2) photocopy or photograph of the chimney plaque;
- 3) system booklet (where applicable).

The installer must ask to be issued with a receipt stating that the documentation has been provided, and must keep it with a copy of the technical documentation relating to the installation.

For installation in a condominium, prior approval from the condominium's administrator must be requested.

Where required, check the exhaust gas emissions after installation. Should a sampling point be installed, it must be airtight.

COMPATIBILITY

Installation in premises with fire hazards is forbidden. Installation in residential premises (except for sealed operation appliances) is also forbidden:

- ♦ in which there are liquid fuel-operated appliances with continuous or intermittent operation, which draw the combustion air in the room in which they are installed, or
- ♦ in which there are type B gas appliances intended for room heating, with or without production of domestic hot water and in adjacent and adjoining premises, or
- ♦ in which, in any case, the depression measured during installation between the internal and external environment is greater than 4 Pa

INSTALLATIONS IN BATHROOMS, BEDROOMS AND STUDIO FLATS

Installation in bathrooms, bedrooms and studio flats is only allowed for sealed or closed hearth appliances with ducted combustion air taken from the outside.

POSITIONING AND SAFETY DISTANCES

The support surfaces and/or points must have a suitable capacity to bear the overall weight of the appliance, accessories and coverings. If the floor is made of a combustible material, we recommend using a non-combustible material to protect the front part from any burnt material which might fall during routine cleaning operations. The generator must be level to function properly. The adjacent, side and rear walls and the supporting surface must be made of non-combustible material.

MINIMUM DISTANCES

Installation next to flammable or heat-sensitive materials is permitted **only if the special safety distances specified on the label at the beginning of the manual (pag.2) are observed**. If the materials are not flammable, you must keep a side and rear distance of at least 100 mm (without the inserts). For products equipped with rear spacers, wall-mounting installation is permitted exclusively for the rear side.

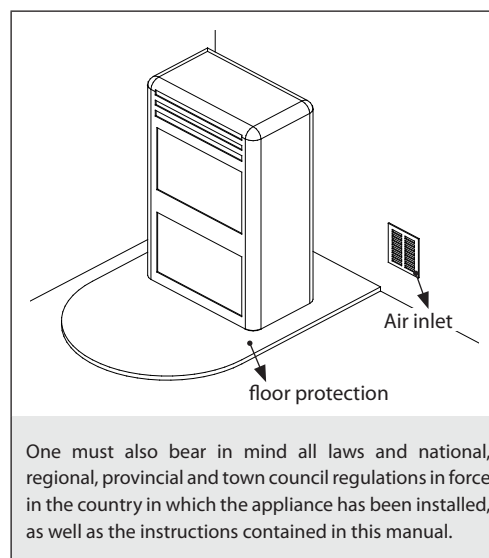

INSTALLING INSERTS

When installing inserts, access must be prevented to the internal parts of the appliance and it must not be possible to access live parts during extraction operations.

Any wiring, for example the power cable or room probe, must be positioned so as not to be damaged during movement of the insert and must not come into contact with hot parts.

VENTILATION AND AERATION OF INSTALLATION ROOMS

Ventilation in the event of a non-hermetic generator and/or of non-sealed installation must take place respecting the minimum area indicated below:

Appliance categories	Reference standard	Percentage of the net opening section with respect to the appliance fumes outlet section	Minimum net opening value of the ventilation duct
Pellet stoves	UNI EN 14785	-	80 cm ²
Boilers	UNI EN 303-5	50%	100 cm ²

Under any condition, including in the presence of extractor hoods and/or of controlled forced ventilation systems, the pressure difference between the generator installation rooms and the outside must always be equal to or less than 4 Pa.

In the presence of type B gas appliances with intermittent operation not intended for heating, they must have their own aeration and/or ventilation opening.

The air inlets must meet the following requirements:

- ♦ they must be protected with grids, metal mesh, etc., but without reducing the net useful section;
- ♦ they must be made so as to make the maintenance operations possible;
- ♦ positioned so that they cannot be obstructed;

The clean and non-contaminated air flow can also be obtained from a room adjacent to that of installation (indirect aeration and ventilation), as long as the flow takes place freely through permanent openings communicating with the outside.

The adjacent room cannot be used as a garage, or to store combustible material or for any other activity with a fire hazard, bathroom, bedroom or common room of the building.

FLUE GAS EXHAUST

The heat generator works in depression and is equipped with an outlet fan for flue gas extraction. There must be a single exhaust system for the generator. Using a flue that is shared with other devices is not allowed.

The components of the flue gas exhaust system must be chosen in relation to the type of appliance to be installed in compliance with:

- ♦ UNI/TS 11278 in the event of metal chimneys, with particular attention to that stated in the specification;
- ♦ UNI EN 13063-1 and UNI EN 13063-2, UNI EN 1457, UNI EN 1806 in the event of non-metallic chimneys.
- ♦ The length of the horizontal section must be minimal and, in any case, no longer than 3 metres, with a minimum upward slope of 3%
- ♦ There must not be more than 4 direction changes including the one due to the use of the "T" element.
- ♦ A "T" fitting with a condensation collection cap must be provided at the base of the vertical section.
- ♦ If the exhaust is not inserted in an existing flue, a vertical section with a windproof end piece is required (UNI 10683).
- ♦ The vertical duct can be inside or outside the building. If the smoke duct is inserted in an existing flue, it must be certified for solid fuel.
- ♦ If the smoke duct is outside the building, it must always be insulated.
- ♦ The smoke ducts must have at least one airtight inlet for flue gas sampling.
- ♦ All the sections of the flue gas duct must be accessible to inspection.
- ♦ Inspection openings must be provided for cleaning.
- ♦ If the generator has a fume temperature lower than 160°C+ ambient temperature caused by the high yield (contact technicians) it MUST be resistant to humidity.
- ♦ A flue system that does not respect the previous points or, in general, that does not comply with the regulations, may cause condensation phenomena inside it.

CHIMNEY CAP

The chimney caps must meet the following requirements:

- ♦ they must have a useful outlet section no less than double that of the chimney/ducted system on which it is installed;
- ♦ they must be adapted in order to prevent the penetration of rain and snow in the chimney/ducted system;
- ♦ they must be built so that, in the event of winds coming from all directions and from any angle, the expulsion of combustion products is in any case ensured;

EXAMPLES OF CORRECT CONNECTION TO THE CHIMNEY

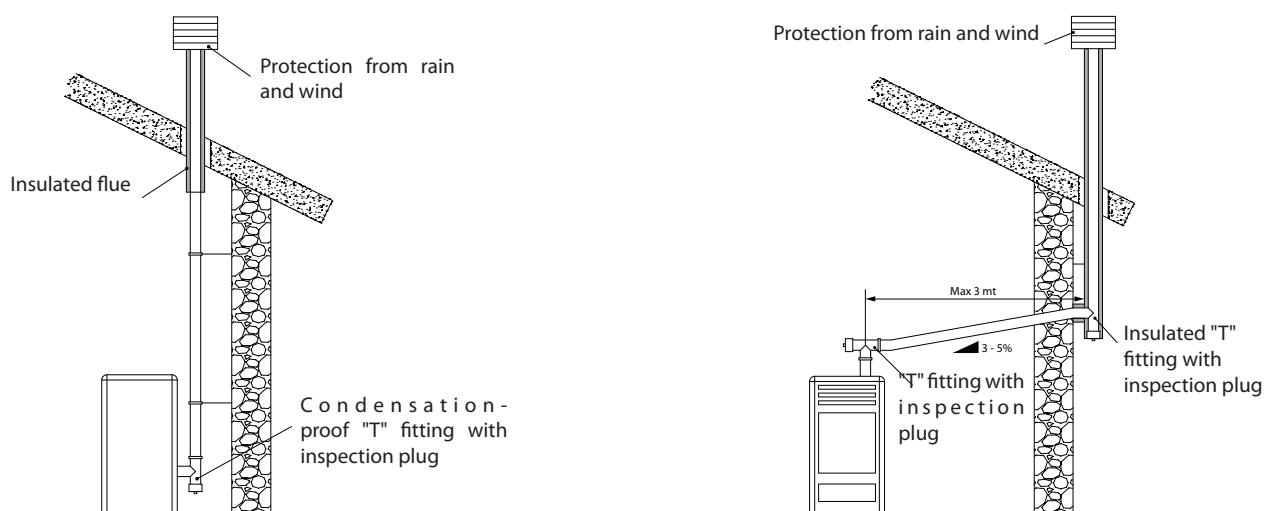

CONNECTION TO THE MAINS ELECTRIC SUPPLY

The generator is supplied with an electric power cable to be plugged into a 230V 50 Hz socket, possibly with a circuit breaker switch. The socket must be easily accessible.

The electrical system must be compliant with standards. The efficiency of the earthing circuit must be checked. Unsuitable earthing of the system can cause malfunctioning for which the manufacturer will not be held liable.

Power supply variations beyond 10% can cause faulty operation of the product.

HERMETIC INSTALLATION

Moira SP is a completely sealed product with respect to the installation environment, which makes it ideal for passive houses, as it does not take air from inside the homes.

COMBUSTION AIR

To respect the air-tight seal of the stove, the combustion air connection pipe must be directly connected to the outside using specific sealed fittings and pipes.

FUMES EXHAUST SYSTEM

- If the generator has a fume temperature below 160°C+ (ambient temperature due to high efficiency, see technical data), the fumes exhaust system must be resistant to humidity.
- Should there be a possibility of the fumes condensating, provide an inspection "T" outside the stove.

INSTALLATION EXAMPLE

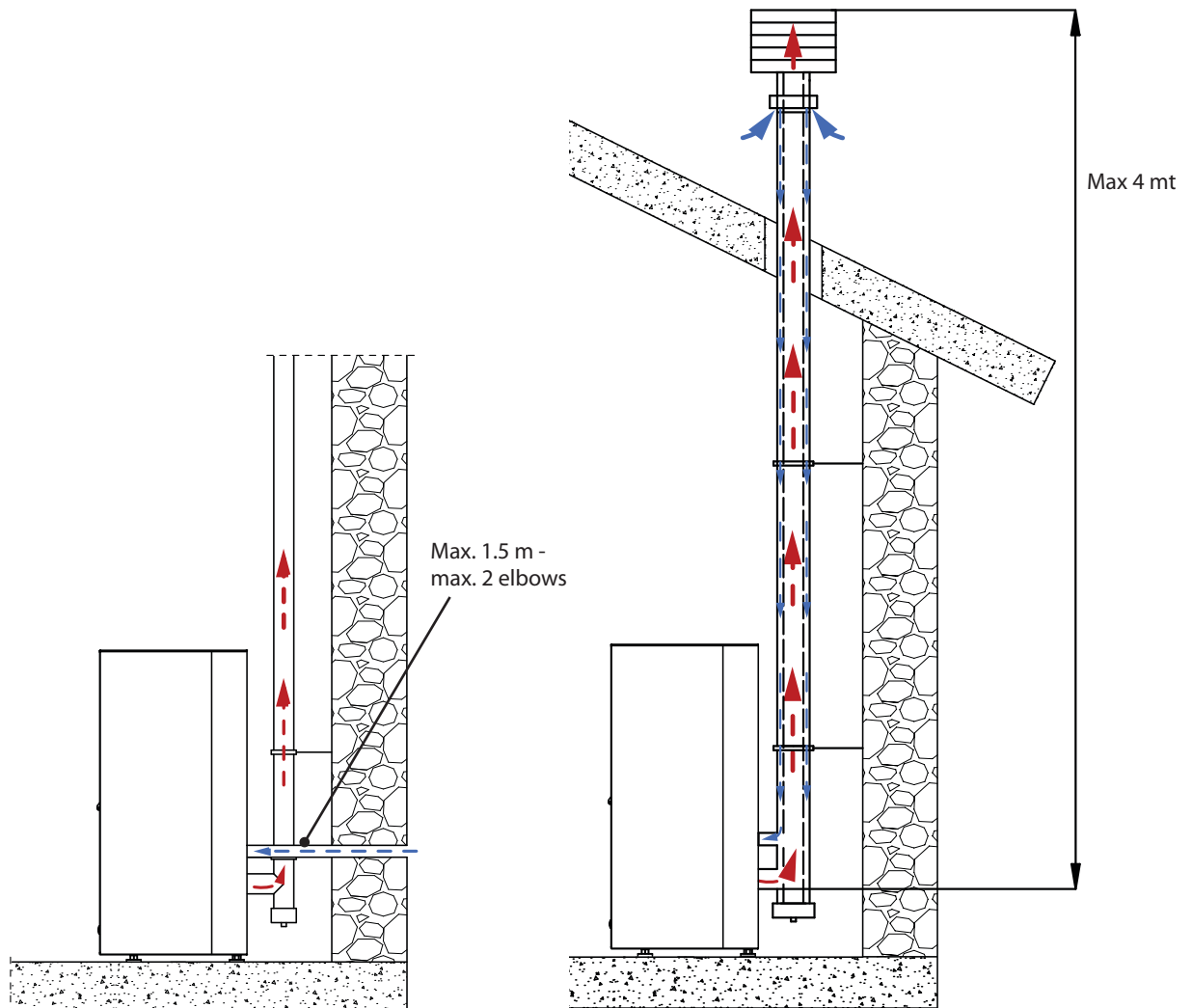

One must also bear in mind all laws and national, regional, provincial and town council regulations in force in the country in which the appliance has been installed, as well as the instructions contained in this manual.

DETAILS OF MOIRA SP

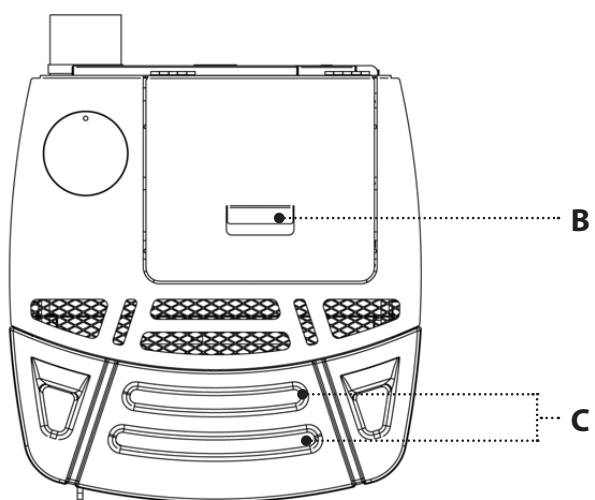
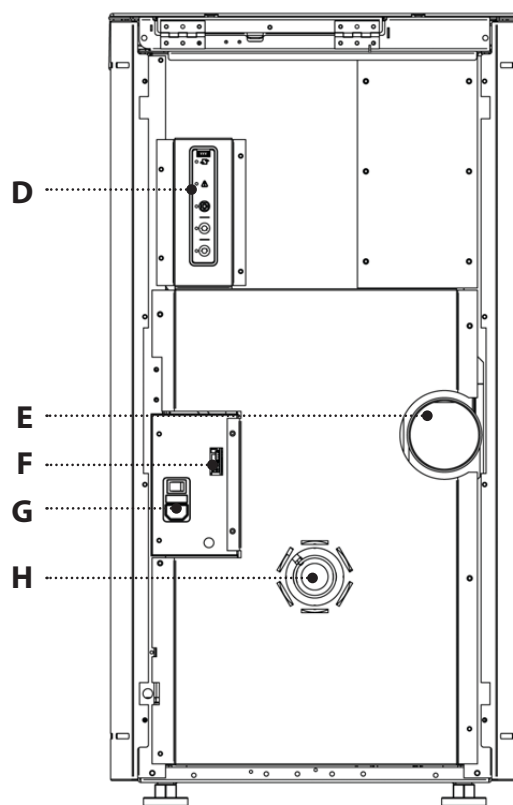
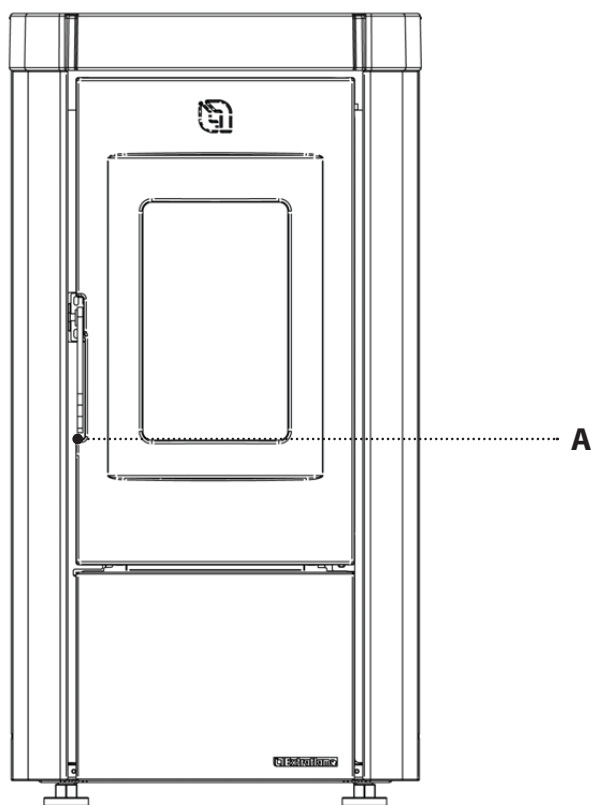

A	Access to combustion chamber and ash drawer	E	Rear fumes exhaust		On/Off
B	Pellet hopper pressurised closure		Serial input	G	Fuse
C	Room air outlet	F	Supplementary thermostat input		230V power supply
D	Radio/emergency board			H	Combustion air inlet

STOVE POSITIONING

For best performance, it is recommended to position the stove in such a way that it is perfectly level, with the aid of a spirit level.

NOTE FOR CORRECT FUNCTIONING

The following indications must be respected for correct pellet stove functioning:

During stove operation, the pellet hopper lid and the door must always be closed.

Failure to comply with that above during operation will cause the display to show the following:

"CLOSE HOPPER-DOOR"

This indication means that you have 60 seconds to close the hatch/door and the pellet lid.

Once 60 seconds have passed, during ignition the stove will go into "DEPR ALARM" mode, while during normal operation the stove will go into "COOLING STAND-BY" mode before automatically restarting when the conditions are satisfied (cold stove, etc.).

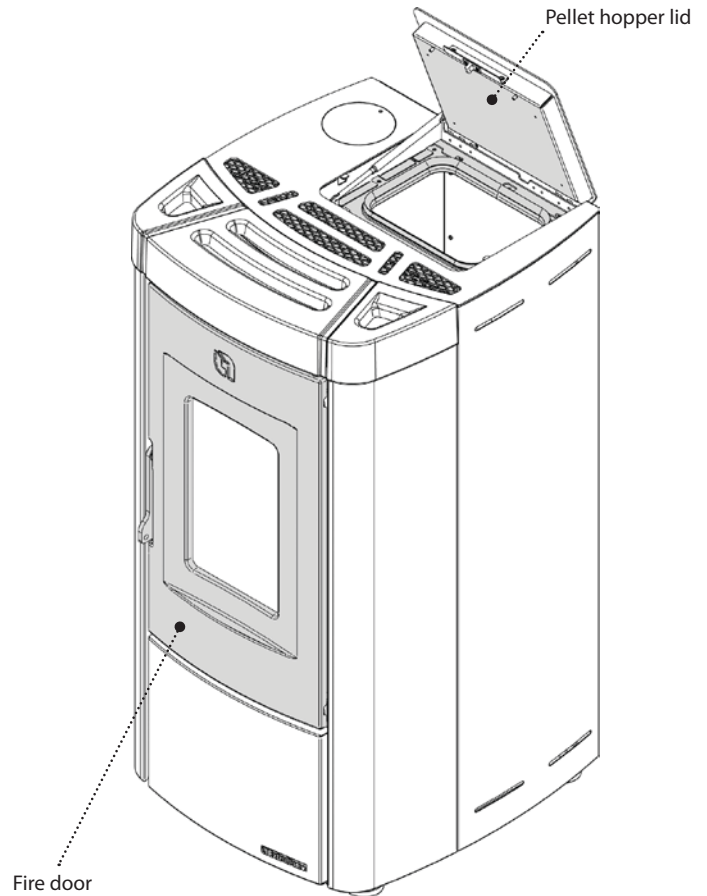

FUSE

If there is no power supply to the stove, check the condition of the fuse located in the box between the stove switch and the power cable connection.

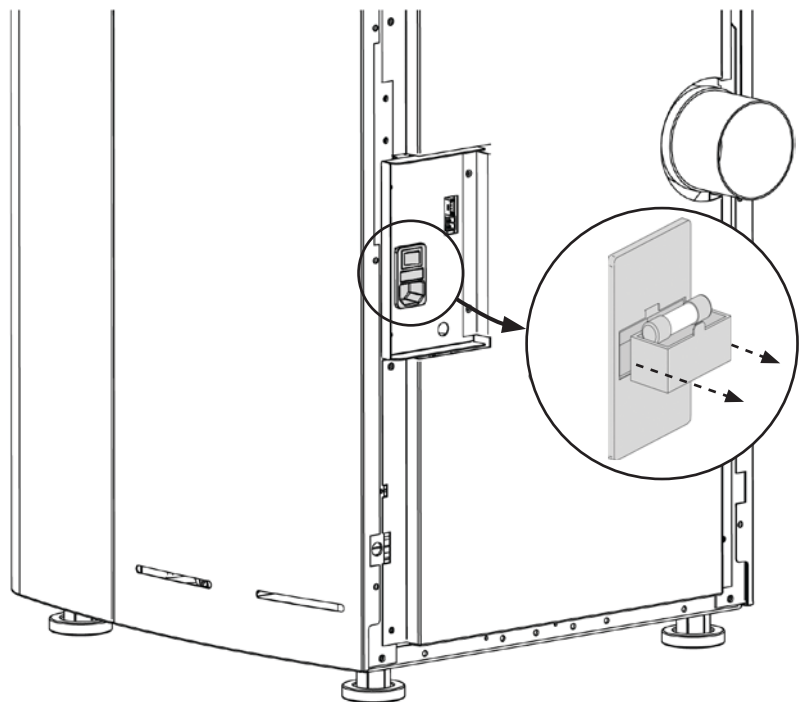

PELLETS AND LOADING

Pellets are made by subjecting wood shavings i.e. the rejects of pure unpainted wood from sawmills, carpentry products and products from other activities connected to wood working and transformation, to very high pressures.

This type of fuel is fully ecological as no glues are used for its compaction. In fact, pellet compactness is guaranteed over time by a natural substance found in wood: lignite.

In addition to being an ecological fuel, making best use of wood residue, pellets also have a series of technical advantages.

While wood has a calorific value of 4.4 kWh/kg (with 15% moisture, therefore after approximately 18 months of curing), that of pellets is 5 kWh/kg.

Pellet density is about 650 kg/m³ and water content is equal to 8% of its weight. For this reason pellets do not need to be cured to obtain a sufficient heat yield.

The pellet type must comply with the specifications set forth by Standards:

- ◆ **EN PLUS - UNI EN 14961 - 2 (UNI EN ISO 17225-2) class A1 - A2**

The Manufacturer recommends using pellets with a diameter of 6mm with its products.

PELLET STORAGE

To guarantee efficient combustion, pellets must be stored in a dry place.

Open the hopper lid and load the pellets using a scoop.

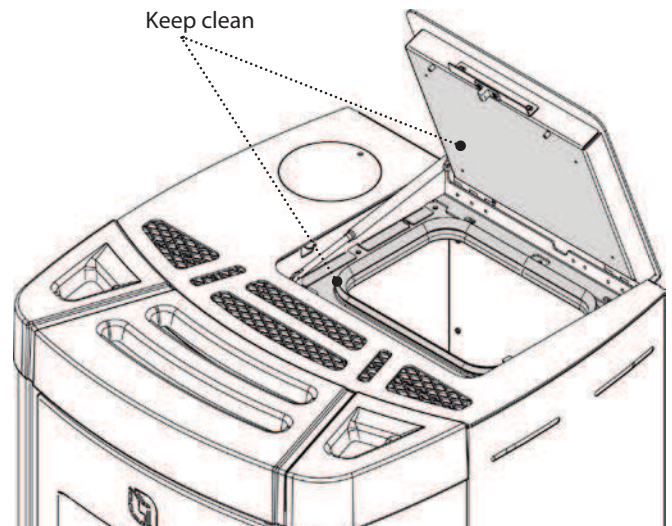

THE USE OF POOR QUALITY PELLETS OR ANY OTHER MATERIAL WILL COMPROMISE STOVE FUNCTIONS, VOIDING THE WARRANTY AND RELEASING THE MANUFACTURER OF LIABILITY.

PELLET HOPPER - PRESSURISED CLOSURE.

During stove operation, the pellet hopper lid must always be closed.

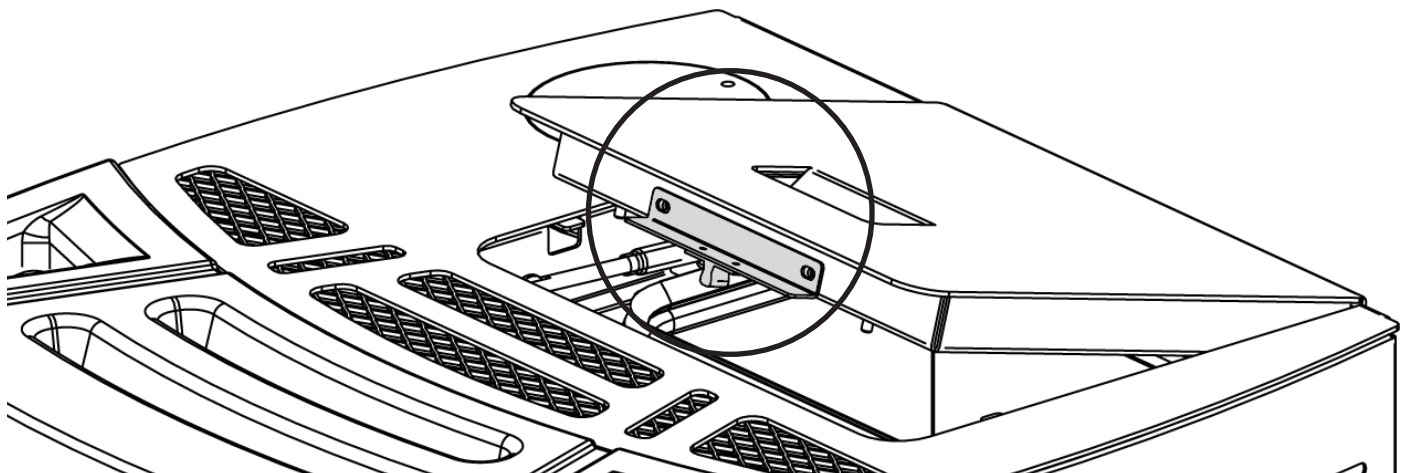

DO NOT PLACE THE BAG DIRECTLY ON THE STOVE TO LOAD THE TANK. ALWAYS USE A SCOOP TO LOAD THE TANK. DO NOT RUB OR PLACE WEIGHTS ON THE TANK SEAL. KEEP THE TANK COVER SEAL SUPPORTING SURFACE CLEAN AT ALL TIMES. CHECK THE CONDITIONS OF THE SEAL FREQUENTLY. IF DAMAGED, CONTACT YOUR LOCAL AUTHORISED TECHNICIAN.

RADIO/EMERGENCY CARD

The stove is fitted with an emergency radio card located at the side, allowing the basic operation of the stove in the event the LCD handheld remote is damaged or malfunctions.

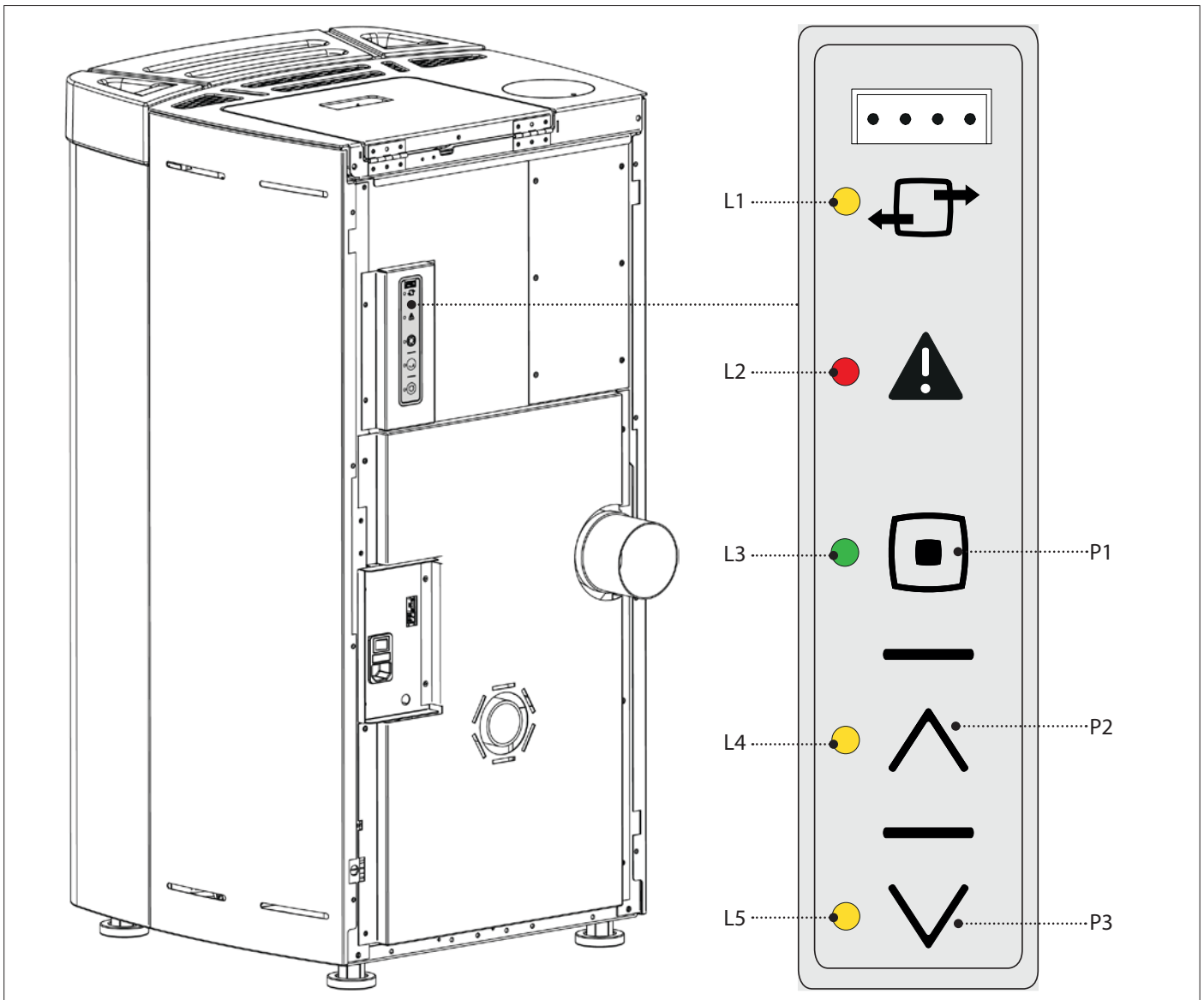



The functions that can be managed from the emergency card are:

	-		
L1: Yellow led	Led off: radio communication not available. Led on: radio communication available.	P1	On/off stove.
L2: Red led	Led off: normal operation. Led on: alarm present.		
L3: Green led	LED off: stove off. Led on: stove on. Flashing led: stove in cleaning phase, alarm, stand-by/ cooling stand-by/or black out stand-by	P2	5th power level setting.
L4: Yellow led	Led on: 5th power level setting (by user).		
L5: Yellow led	Led on: 1st power level setting (by user).	P3	1st power level setting.

HANDHELD CONFIGURATION

HANDHELD CODING PROCEDURE:

1. Disconnect the power supply to the stove.
2. Press keys  and **OK** at the same time until the *UNIT* selection screen appears.
3. Using keys  and  select the new *UNIT*.
4. Power the stove. Confirm the selected unit within 10 seconds (all LEDs flash on the radio/emergency card) by pressing the OK key on the handheld.
5. All LEDs on the radio/emergency card will remain on for 2 seconds to confirm the new configuration.
6. If configuration was unsuccessful, the display will read "**DEVICE NOT FOUND**". In this case, repeat the procedure.



THE HANDHELD IS ALREADY CONFIGURED WITH "UNIT 0". IF THERE IS ANOTHER STOVE, A NEW CONFIGURATION MUST BE PERFORMED BY MODIFYING ONE OF THE TWO STOVES, TO AVOID ANY INTERFERENCE.





SOME RADIO FREQUENCY DEVICES (E.G. MOBILE PHONES, ETC...) MAY CAUSE INTERFERENCE WITH COMMUNICATION BETWEEN THE HANDHELD AND THE STOVE.

HANDHELD ROOM PROBE CALIBRATION

This mode allows the room temperature detected by the handheld to be calibrated (only with ventilation enabled). For correct calibration, it is advisable to place the handheld in an environment with a constant temperature and to wait at least a couple of hours.

The procedure for calibration is the following:

- ♦ Access the menu and open the "**TECHNICAL MENU**".
- ♦ Set the access key "F4". - "**ADJ SONDA TELE**"
- ♦ Using the keys  or  adjust the calibration of the desired room temperature.
- ♦ Save and exit using the key .

BATTERY TYPE AND REPLACEMENT

To insert/replace the batteries, suffice it to remove the battery protection cover at the back of the handheld device (figure 1). Insert the batteries in accordance with the symbols imprinted on the handheld device and on the battery itself.

Three AAA batteries are required for the handheld device to function.

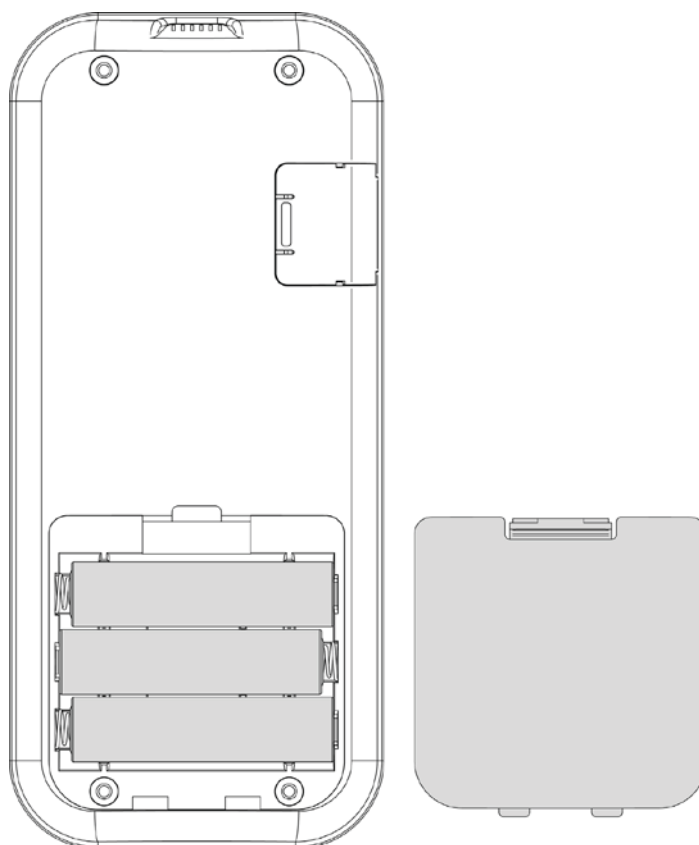

(figure 1)



Respect the environment!

Used batteries contain metals that are harmful to the environment, and therefore must be disposed of separately in special containers.

HANDHELD FEATURES

- ◆ The handheld device is fitted with an LCD backlit display. The display remains lit for 5 seconds. After a certain period of time, in order to minimise battery consumption, the display turns off (sleep mode).
- ◆ It turns on again after pressing the ON/OFF key (6).

◆ **CAUTION!**

- ◆ Do not place the handheld device in direct or indirect contact with water. The handheld device may not work properly in the presence of humidity or if exposed to water.

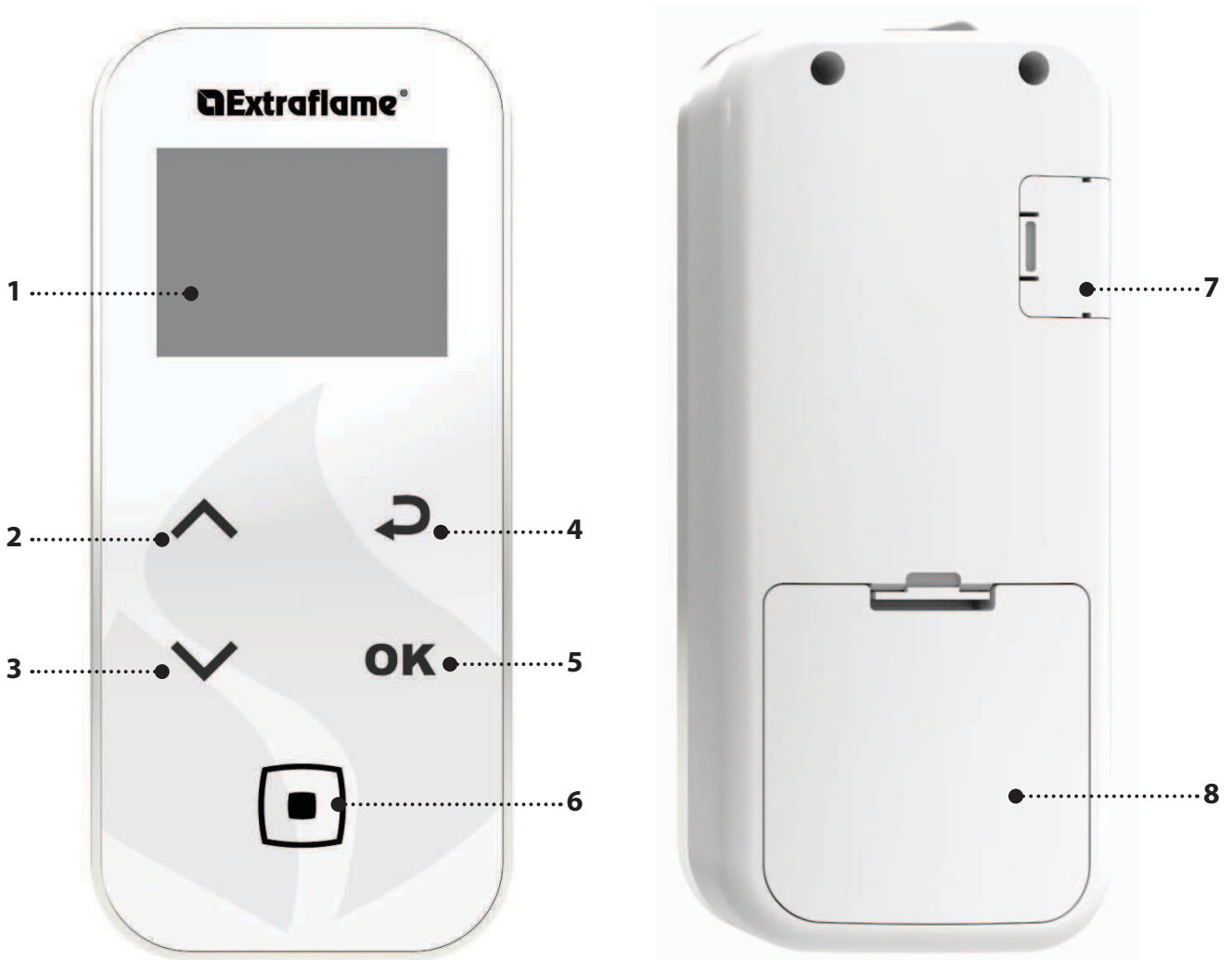

1.	DISPLAY
2.	SET POWER/ scroll menus / increase - select a setting
3.	SET THERMOSTAT ambient/ scroll menus / decrease - deselect a setting
4.	Back key
5.	Key to access MENU and CONFIRM
6.	Stove on/off or restore from sleep mode.
7.	-
8.	Battery compartment

FREQUENCY BANDS	MAXIMUM POWER TRANSMITTED
868,3 MHz	4 mW ERP
869,85 MHz	4 mW ERP

DISPLAY

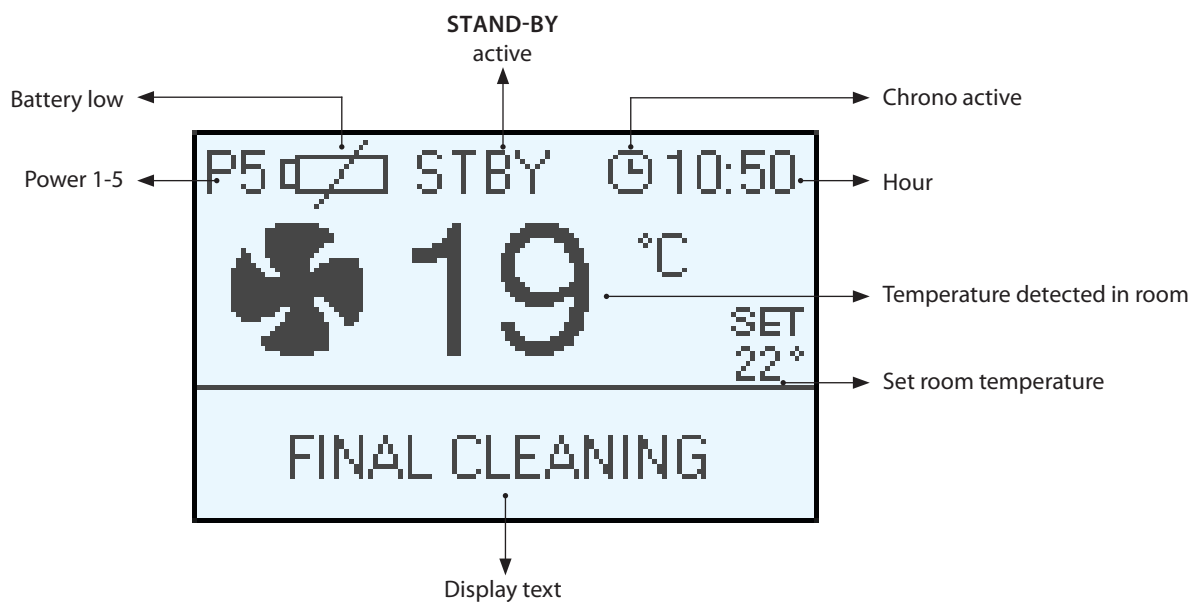

SCREEN IN OPERATION

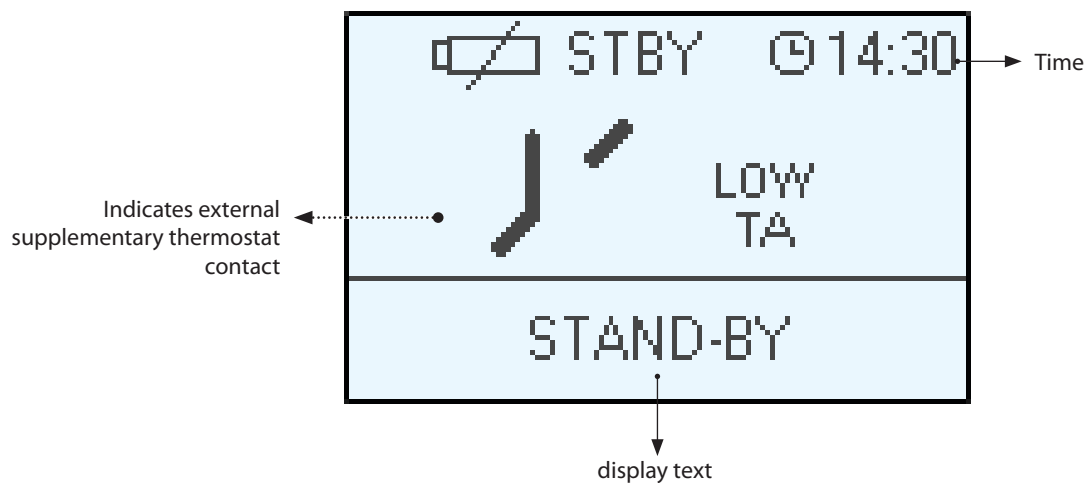

SCREEN WITH EXTERNAL THERMOSTAT CONNECTED TO THE TERMINAL "TA"



GENERAL MENU

KEY	FUNCTION
	Scroll parameters Modify settings
	On / off key

KEY	FUNCTION
	Back - exit key
OK	Access menu key

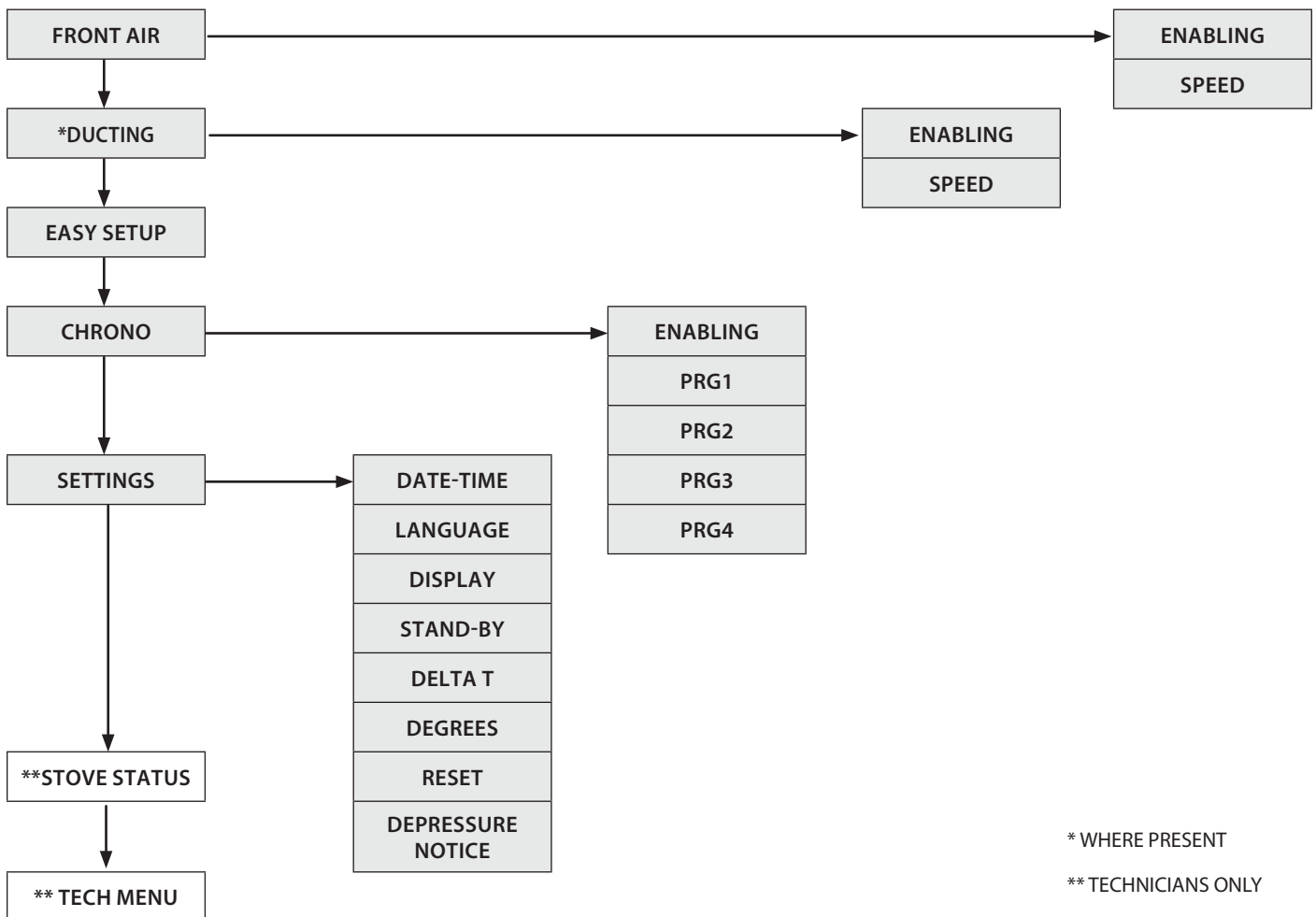

BASIC INSTRUCTIONS

The following recommendations must be followed during the initial stove ignitions:

- ♦ It is possible that slight odours are produced due to the drying of the paints and silicone used. Do not remain in the room for long periods.
- ♦ Do not touch the surfaces as they could still be unstable.
- ♦ Ventilate the room well several times.
- ♦ The hardening of surfaces will stop after several heating cycles.
- ♦ This appliance must not be used to burn waste.

Before lighting the stove, the following points must be checked:

- ♦ The hopper must be full of pellets
- ♦ The combustion chamber must be clean
- ♦ The burn pot must be completely free and clean
- ♦ Check the hermetic closure of the hopper, fire door and ash drawer
- ♦ Check that the power cord is properly connected
- ♦ The bipolar switch in the rear right part must be positioned on 1.

FIRST START-UP SETTINGS

Once the power cord at the back of the generator has been connected, move the switch, also located at the back, to (I).

The switch at the back of the generator powers the generator board.
The generator remains off and a first screen appears on the panel reading OFF.

LINE FREQUENCY 50/ 60HZ

If the generator is installed in a country with a frequency of 60Hz, the generator will display "POWER FREQUENCY ERROR". In this case, adjust the frequency to 60Hz.

DATE-TIME

This menu allows the date and time to be set.

To set: OK > SETTINGS > DATE-TIME.

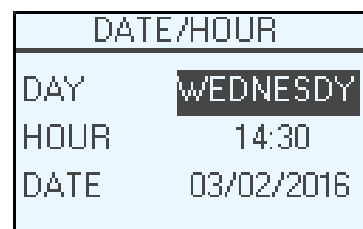

LANGUAGE

This menu allows the preferred language to be selected.

To set: OK > SETTINGS > LANGUAGE.

The selectable languages are: Italian, English, French, German, Spanish, Portuguese.



SET DEGREES

This menu allows the desired unit of measurement to be set.

To set: OK > SETTINGS > DEGREES.

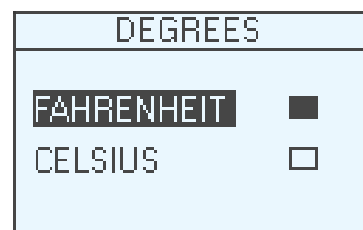

DO NOT USE ANY TYPE OF FLAMMABLE LIQUIDS FOR IGNITION!
DO NOT ALLOW THE BAG OF PELLETS TO COME INTO CONTACT WITH THE BOILING HOT STOVE DURING THE FILLING PHASE!
IN THE EVENT OF CONTINUED FAILURE TO LIGHT, CONTACT AN AUTHORISED TECHNICIAN.



NO IGNITION

THE APPLIANCE MAY FAIL TO LIGHT BECAUSE THE AUGER IS EMPTY AND NOT ALWAYS ABLE TO LOAD THE BURN POT FAST ENOUGH WITH THE PELLETS NEEDED FOR NORMAL IGNITION.
IF THE PROBLEM OCCURS AFTER ONLY A FEW MONTHS OF OPERATION, CHECK THAT THE ROUTINE CLEANING DESCRIBED IN THE STOVE HANDBOOK HAS BEEN CARRIED OUT CORRECTLY.



IT IS FORBIDDEN TO USE THE DEVICE WITHOUT A PARTITION (A) AND FLAME GUARD (B).
REMOVAL WILL COMPROMISE THE SAFETY OF THE PRODUCT AND RESULT IN THE IMMEDIATE NULLIFICATION OF THE WARRANTY PERIOD.
IN THE EVENT OF WEAR OR DETERIORATION, REQUEST THE PART'S REPLACEMENT FROM THE AFTER-SALES SERVICE.
(REPLACEMENT IS NOT COVERED BY THE PRODUCT WARRANTY AS THE PART IS SUBJECT TO WEAR).

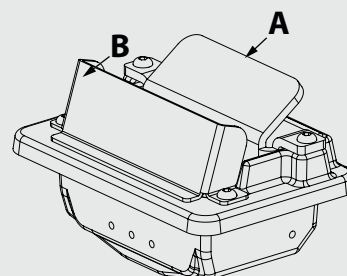

FUNCTIONING AND LOGIC

IGNITION

Once the previously listed points have been checked, press the key  for three seconds until the stove lights up. During ignition, the stove will check for a flame for a period of 15 minutes. Once the limit temperature has been reached, the stove interrupts the ignition phase and switches to PREPARATION.

PREPARATION

During the preparation phase, the stove stabilises, progressively increasing combustion, before enabling ventilation and switching to WORK

WORK

In work mode, the stove works at the SET POWER defined by the user, heating the environment until reaching the SET THERMOSTAT. See next heading.

REGULATION OF SET THERMOSTAT

The room SET THERMOSTAT can be set using buttons 2 and 3, from LOW-TA - 7°C - 40°C - HOT. If the value is between 07°C-40°C the stove checks the room temperature using a probe incorporated in the handheld. Once the set temperature has been reached, the stove automatically reduces the power, guaranteeing optimal comfort and reducing pellet consumption: this process is called "modulation".

LOW-TA - HOT



If the SET THERMOSTAT is "LOW-TA" (set below the limit of 7°) temperature control is entrusted to the supplementary thermostat contact. The temperature probe incorporated into the handheld is thus ignored.

If the contact is open (satisfied), the stove will work at the minimum power level.

If the contact is closed (request), the stove will always work at the set power level.

If the setting is on "HOT" (set above 40°C) the stove will always and only work at the set power level, thus ignoring the external contact and temperature probe.

REGULATION OF SET POWER

The set power has 5 operating levels. When the  key is pressed, the set power is displayed, which can be edited using the keys  or .

Power 1 = minimum level - Power 5 = maximum level.

Changes must be confirmed by pressing the key **OK**.

To set power 1 it is necessary to press and hold the key  for 3 seconds.

AUTO BLOW

During the work phase and at regular intervals, the stove cleans the bun pot. This process is known as "AUTO BLOW".

When this function is activated, it is shown on the display with a message. During "AUTO BLOW" pellet loading is slowed and the fumes motor speeds up.

At the end of cleaning, the stove returns to work mode in normal operating conditions.

SWITCH-OFF

Press the  key for three seconds.

Once this operation has been performed, the appliance automatically enters the switch-off phase, blocking the supply of pellets.

The fume extraction motor and the hot air flow motor will remain on until the stove temperature has dropped below the safety limit.

RE-IGNITION

The stove can be re-ignited only if the fumes temperature is less than the preset limit, and if the minimum safe time has passed.

FRONT AIR

From the menu, it is possible to enable/disable and adjust the front air speed (-2, -1, 0, +1, +2).

To enable: *OK* > *FRONT AIR* > *ENABLE*

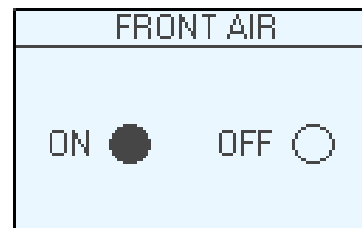

To adjust the speed : *OK* > *FRONT AIR* > *SPEED*

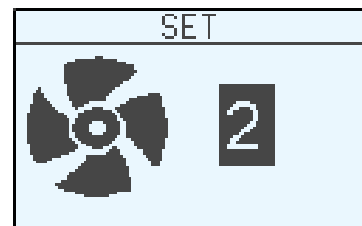

EASY SETUP

The volumetric pellet weight is the ratio between the pellet weight and pellet volume. This ratio can change maintaining the quality of the pellet unaltered. Using the **EASY SETUP** function, it is possible to change the calibration of the volumetric weight, increasing or decreasing the set values. In the stove program, the values available go from “- 3” to “+ 3”; all stoves are calibrated on production with the default value, which is 0

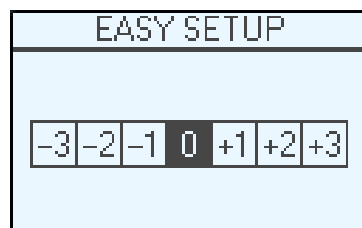

If you notice an excessive deposit in the burn pot, access the **EASY SETUP** program and lower the value by one unit to “- 1”; then wait until the next day and if there is no improvement, decrease again, to a maximum of “- 3”. If on the other hand the volumetric pellet weight calibration needs to be increased, change the value from the factory setting of “0” to “+1, +2, +3” as required.

To set: *OK* > **EASY SETUP**

EXCESSIVE PELLETT DEPOSIT IN BURN POT			NORMAL OPERATION	LOW PELLETT DEPOSIT IN BURN POT		
-3	-2	-1	0	+1	+2	+3
THIRD DECREASE RANGE IF THE FIRST TWO ARE INSUFFICIENT	SECOND DECREASE RANGE IF THE FIRST IS INSUFFICIENT	FIRST DECREASE RANGE (TEST FOR 1 DAY)	OPTIMAL FACTORY VALUE	FIRST INCREASE RANGE	SECOND INCREASE RANGE IF THE FIRST IS INSUFFICIENT	THIRD INCREASE RANGE IF THE FIRST TWO ARE INSUFFICIENT

N.B.: If this calibration does not rectify the pellet deposit level in the burn pot, contact your local after-sales service centre.

CHRONO

This function allows the programming of automatic stove ignition and switch-off.

By factory default **CHRONO** is disabled.

The chrono allows the programming of 4 time slots within a day, which can be used every day of the week.

For each time slot, it is possible to set ignition and switch-off times, specific days of application, desired temperature and set power. Current day and time settings are essential for the correct operation of the Chrono.

Recommendations

Before using the chrono function, the current day and time need to be set. Therefore, check that the steps listed in the sub-chapter "SET CLOCK" have been carried out. For the chrono to work properly, it must be programmed and then enabled. The 4 time slots can be linked through the switch-on and switch-off times. In this way, it is possible to create a combination of time slots with different temperatures and power levels, without changing the status of the stove.

N.B.: in the case of multiple linked time slots, the product will remain on until the last switch-off time.

ENABLING

Allows the chrono and the different stove time slots to be enabled/disabled.

To set: *OK > CHRONO > ENABLE.*

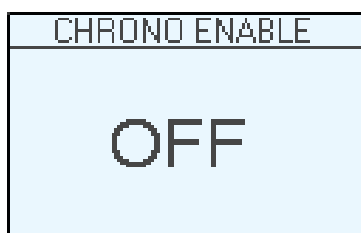

PRG 1-4

Prg x allows to set the on/off time, the days of use of the scheduled time slot, the desired temperature (low - 7° - 40° - hot) and also the desired power level. Current day and time settings are essential for the correct operation of the Chrono.

To set: *OK > CHRONO > PRGX*

<p>1. Enable prg x</p> <p>A screenshot of a digital display showing the menu 'ENABLE PRG1' at the top and the status 'OFF' in the center.</p>	<p>2. On time prg x</p> <p>A screenshot of a digital display showing the menu 'START PRG 1' at the top and the time '10:00' in the center.</p>
<p>3. Off time prg x</p> <p>A screenshot of a digital display showing the menu 'STOP PRG 1' at the top and the time '22:30' in the center.</p>	<p>4. Enable days prg x</p> <p>A screenshot of a digital display showing the menu 'MONDAY' at the top and the status 'ON' in the center.</p>
<p>5. Set temperature prg x</p> <p>A screenshot of a digital display showing the menu 'SET PRG1' at the top and the temperature '35' in the center.</p>	<p>6. Set power prg x</p> <p>A screenshot of a digital display showing the menu 'POWER PRG1' at the top and the power level '4' in the center.</p>

CHRONO

ENABLING

Enable/disable entire set chrono

∨

PRG1

ENABLE PRG 1

On/off

Enable/disable PRG 1

∨

START PRG1

OFF-00:00-23:50

On time PRG1

∨

STOP PRG1

OFF-00:00-23:50

Off time PRG1

∨

MONDAY...SUNDAY

On/off

Enable/disable days of PRG1

∨

SET PRG1

LOW-TA - 07- 40 °C - HOT

Set thermostat PRG1

∨

POWER PRG1

1-5

Set power PRG1

∨

PRG2

ENABLE PRG 2

On/off

Enable/disable PRG 2

∨

START PRG2

OFF-00:00-23:50

On time PRG2

∨

STOP PRG2

OFF-00:00-23:50

Off time PRG2

∨

MONDAY...SUNDAY

On/off

Enable/disable days of PRG2

∨

SET PRG2

LOW-TA - 07- 40 °C - HOT

Set thermostat PRG2

∨

POWER PRG2

1-5

Set power PRG2

∨

PRG3

ENABLE PRG 3

On/off

Enable/disable PRG 3

∨

START PRG3

OFF-00:00-23:50

On time PRG13

∨

STOP PRG3

OFF-00:00-23:50

Off time PRG3

∨

MONDAY...SUNDAY

On/off

Enable/disable days of PRG3

∨

SET PRG3

LOW-TA - 07- 40 °C - HOT

Set thermostat PRG3

∨

POWER PRG3

1-5

Set power PRG3

∨

PRG4

ENABLE PRG 4

On/off

Enable/disable PRG 4

∨

START PRG4

OFF-00:00-23:50

On time PRG4

∨

STOP PRG4

OFF-00:00-23:50

Off time PRG4

∨

MONDAY...SUNDAY

On/off

Enable/disable days of PRG4

∨

SET PRG4

LOW-TA - 07- 40 °C - HOT

Set thermostat PRG4

∨

POWER PRG4

1-5

Set power PRG4



WHEN THE WEEKLY PROGRAMMER IS ACTIVE, THE RELATIVE ICON WILL BE SHOWN ON THE HANDHELD DISPLAY.



EXAMPLE OF CHRONO WITH LINKED TIMES/TIME SLOTS

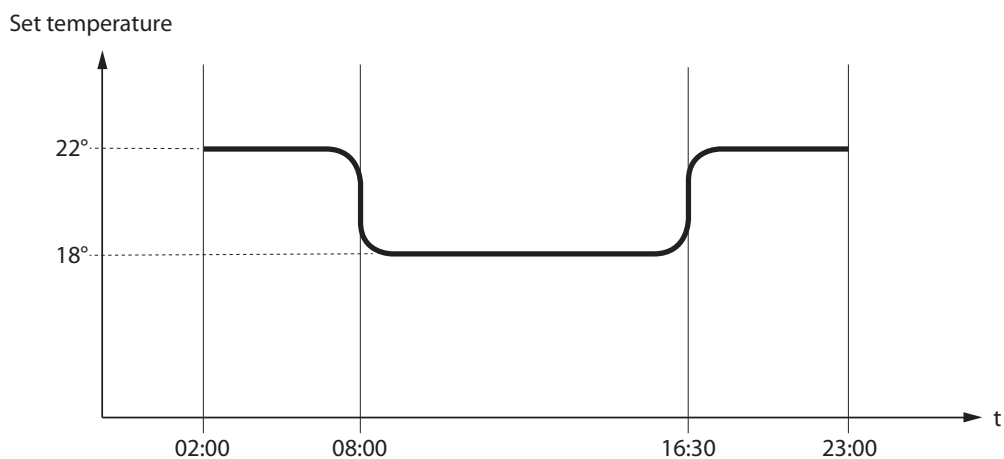
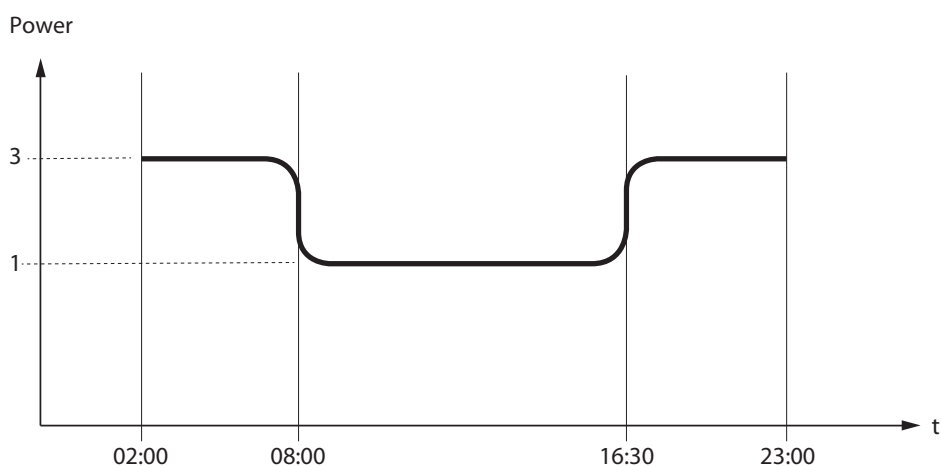
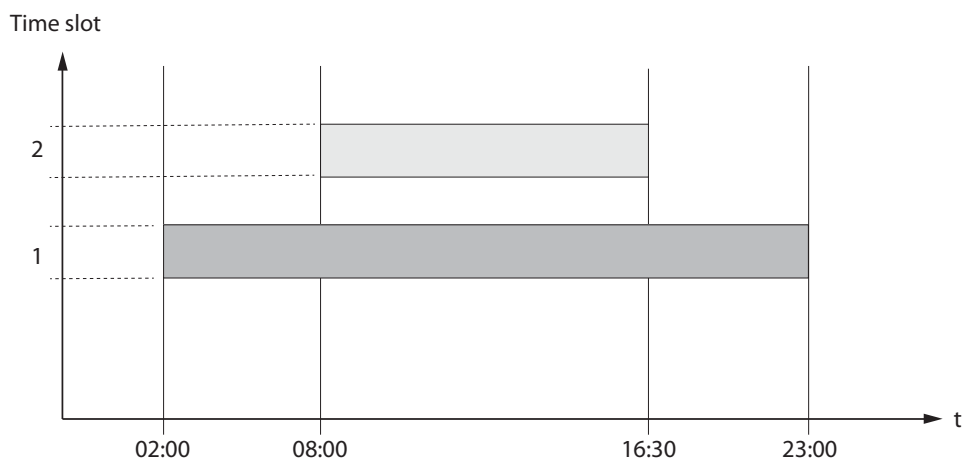

	Time slot 1	start 02:00 stop 23:00	power 3 - set temp 22°C
	Time slot 2	start 08:00 stop 16:30	power 1 - set temp 18°C
	stove functioning		

SETTINGS

- ◆ DATE-TIME
- ◆ LANGUAGE
- ◆ SET DEGREES

SEE CHAPTER: FIRST START-UP SETTINGS.

DISPLAY

The "DISPLAY" menu allows:

- ◆ Regulation of DISPLAY contrast
- ◆ Activation/Deactivation of backlight.
- ◆ Enabling/disabling of acoustic signal.
- ◆ Set timer for Display backlight switch-off.
- ◆ Set timer for Display switch-off (sleep mode).

DISPLAY	
CONTRAST	25
BRIGHTNESS	ON
BUZZER	ON
STAND-BY	4sec
RESET	20sec

To set: *OK > SETTINGS > DISPLAY.*

STAND-BY

The STAND-BY function is used for immediate stove switch-off as opposed to power modulation.

To set: *OK > SETTINGS > STAND-BY.*

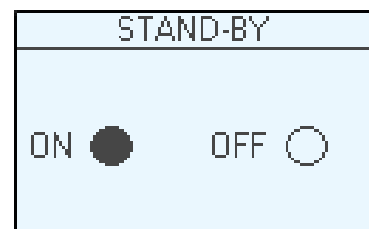

STAND-BY FUNCTION SET TO ON

When the STAND-BY function is enabled (ON), if the room temperature exceeds the SET THERMOSTAT value + DELTA T, the stove switches off after a preset factory delay, and STAND-BY will be displayed on the screen.

When the room temperature is less than SET THERMOSTAT - DELTA T and after a certain cooling time, the stove will switch on again.

STAND-BY FUNCTION SET TO OFF (FACTORY SETTING)

When the STAND-BY function is not enabled (OFF), if the stove exceeds the set room temperature, it will switch to the minimum power level, modulating and displaying 'modulation' on the screen. When the room temperature is lower than SET THERMOSTAT the stove will work at the set power level, and 'work' will be displayed on the screen.

FUNCTIONING WITH SUPPLEMENTARY THERMOSTAT (OPTIONAL)

STAND-BY FUNCTION SET TO OFF (FACTORY SETTING)

When the STAND-BY function is not enabled (OFF), if the stove exceeds the room temperature set on the supplementary thermostat (closed contact), it will switch to the minimum power level and MODULATION will be displayed on the screen. When the room temperature is lower than the set value on the supplementary thermostat (open contact), the stove will start to work again at the set power, and WORK will be displayed on the screen.

STAND-BY FUNCTION SET TO ON

If the STAND-BY function is enabled (ON), when the room temperature set on the supplementary thermostat is reached (closed contact), the stove will switch off after a preset (default) delay period, and STAND - BY will be displayed on the screen.

When the room temperature is less than the set temperature on the supplementary thermostat (open contact), and after a certain cooling time, the stove will switch on again.



FOR CORRECT FUNCTIONING, SET THE ROOM TEMPERATURE TO LOW-TA
> SEE CHAPTER ON INSTALLATION OF SUPPLEMENTARY THERMOSTAT

DELTA T

This function allows the hysteresis limit to be set for stove switch-on and switch-off *DELTA T*, used as an interval of regulation in the event the room temperature is not managed by an external thermostat. The exact switch-on temperature is *SET THERMOSTAT - DELTA T*. The switch-off temperature is *SET THERMOSTAT + DELTA T*.

Possible *DELTA-T* values range from: 0.5 - 5°C.

To set: *OK > SETTINGS > DELTA-T*

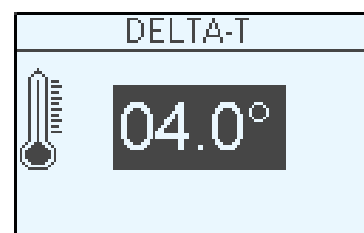

RESET

Allows the user to restore all editable values to the default values.

To set: *OK > SETTINGS > RESET*.



DEPRESSURE NOTICE

It allows to activate the warning buzzer if the door or hopper is open.

Please note: activating this buzzer may reduce battery life by 30%.

Battery life depends on use.

To set: *OK > SETTINGS > DEPRESSURE NOTICE*

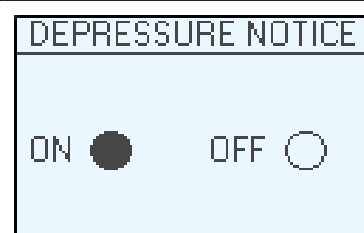

ADDITIONAL FUNCTIONS

FIRST LOAD

This function enables the pellet loading gear motor for continuous functioning.

Before enabling this function, make sure the stove is cold and in "OFF" mode. Press buttons 6 + 4 at the same time for a few seconds until "FIRST LOAD" appears on the screen.

To interrupt continuous loading, simply hold key 6 down for 2 seconds.

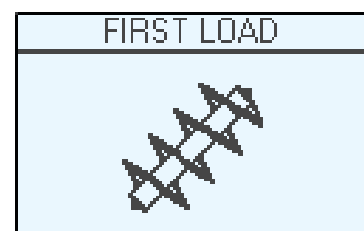

INSTALLATION OF SUPPLEMENTARY THERMOSTAT (OPTIONAL)

The appliance is able to control the room temperature through a supplementary thermostat (optional).

After the stove is switched on (by pressing 1 or in chrono mode), it will work to reach the set thermostat temperature, displaying WORK (open contact) on the screen. The room sensor supplied standard will automatically be ignored.

When the thermostat reaches the temperature (closed contact) the stove will work at the minimum power level, displaying MODULATION ON THE SCREEN.

CONTROLS PROCEDURE

- ♦ A mechanical or digital thermostat is needed with a "normally open" input type.
- ♦ Remove the plug from the socket.
- ♦ Using the image to the side as a guide, connect the two thermostat wires (clean contact - no 230 V!) to the respective terminals at the back of the machine, one red and the other black.
- ♦ Connect the power to the stove again.
- ♦ Press key 3 until SET THERMOSTAT is set to LOW-TA.

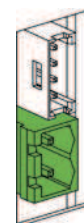

INSTALLATION MUST BE PERFORMED BY QUALIFIED STAFF AND/OR THE MANUFACTURER'S AFTER-SALES TECHNICIANS.

DELAYED SWITCH-OFF

The appliance can be programmed for delayed switch-off. For example, if it is 8.00pm and delayed switch-off is set to 1 hour, at 9.00pm the stove will automatically switch off.

When keys 6 + 2 are pressed and held, the "DELAYED SWITCH-OFF" screen opens up (this setting can only be configured when the machine is in preparation or work mode).

Using keys 2 and 3, it is possible to increase/decrease the number of hours after which the stove will enter the final cleaning phase on its own. The possible hours range between OFF, and 1 to 9.

When P6 is pressed, the setting is confirmed and the user returns to the home screen.

1 hour before the set switch-off time, the remaining work time is indicated and the message "switch-off in" and value "HOURS xx:xx" is displayed.

TO FIND OUT WHERE YOUR NEAREST SERVICE CENTRE IS, CONTACT YOUR DEALER OR GO TO THE WEBSITE:
WWW.LANORDICA-EXTRAFLAME.COM

CLEANING AND MAINTENANCE

ALWAYS FOLLOW THE INSTRUCTIONS WITH MAXIMUM SAFETY!

- ♦ Make sure that the power cord is unplugged because the generator may have been programmed to switch on.
- ♦ That the generator is cold all over.
- ♦ The ashes are completely cold.
- ♦ Ensure efficient air exchange in the room during the product cleaning operations.
- ♦ Poor cleaning will compromise correct operation and safety!

MAINTENANCE

For correct operation, the generator must undergo routine maintenance by a qualified technician, at least once a year. The periodic inspection and maintenance operations must always be performed by specialised, qualified technicians, who operate in accordance with the laws in force and the instructions given in this use and maintenance manual.



EVERY YEAR, HAVE THE FUME EXTRACTION SYSTEM, THE FUMES EXHAUST PIPES AND THE "T" FITTINGS AND INSPECTION CAPS CLEANED - IF PRESENT, ALSO THE ELBOWS AND HORIZONTAL SECTIONS! THE GENERATOR CLEANING FREQUENCY IS INDICATIVE! IT DEPENDS ON THE QUALITY OF THE PELLETS USED AND ON THE FREQUENCY OF USE. SOMETIMES THESE OPERATIONS MUST BE PERFORMED MORE OFTEN.

PERIODIC CLEANING UNDER USER RESPONSIBILITY

The periodic cleaning operations, as indicated in this use and maintenance manual, must be performed with the utmost care after reading the instructions, procedures and frequency described in this use and maintenance manual.

CLEANING THE SURFACES AND COVERING

Never use abrasive or chemically aggressive detergents for cleaning!

The surfaces must be cleaned when the generator and covering are completely cold. For the maintenance of the surfaces and metal parts, simply use a cloth dampened with water, or with water and a neutral soap. Failure to comply with these instructions may damage the surfaces of the generator and cause the invalidation of the warranty.

CLEANING THE CERAMIC GLASS

Never use abrasive or chemically aggressive detergents for cleaning!

The ceramic glass must be cleaned when the glass is completely cold. To clean the ceramic glass, simply use a dry brush and some damp newspaper dipped in ash. If the glass is very dirty, use a specific cleaning agent for ceramic glass. Spray a small amount on a cloth and use it on the ceramic glass. Do not spray the cleaning agent or any other liquid directly on the glass or seals!

Failure to comply with these instructions may damage the surfaces of the ceramic glass and cause the invalidation of the warranty.

CLEANING THE PELLET HOPPER

When the hopper is completely empty, disconnect the power cable of the generator, remove the residue (dust, chippings, etc.) from the empty hopper and then fill it up.



THE PELLET HOPPER GASKETS, BURN POT AND FIRE DOOR GUARANTEE CORRECT STOVE OPERATION. THESE NEED TO BE PERIODICALLY CHECKED BY THE USER. IF THEY ARE WORN OR DAMAGED, IMMEDIATELY REPLACE THEM. THESE OPERATIONS MUST BE CARRIED OUT BY A QUALIFIED TECHNICIAN.



IF THE POWER SUPPLY CABLE IS DAMAGED, IT MUST BE REPLACED BY THE AFTER-SALES SERVICE OR BY A SIMILARLY QUALIFIED PERSON, SO AS TO AVOID ALL RISKS.

EVERY DAY BURN POT AND COMBUSTION CHAMBER:

- ♦ Extract any residue in the burn pot
- ♦ Completely remove the burn pot from the relevant compartment;
- ♦ Extract the ash from the burn pot housing, ignition plug holder tube and combustion chamber.
- ♦ Free all the holes in the burn pot using the poker supplied.
- ♦ Re-position the burn pot in its housing and push it towards the fire wall.

NOTE: Use a suitable ash vacuum cleaner with a container to separate the ash.

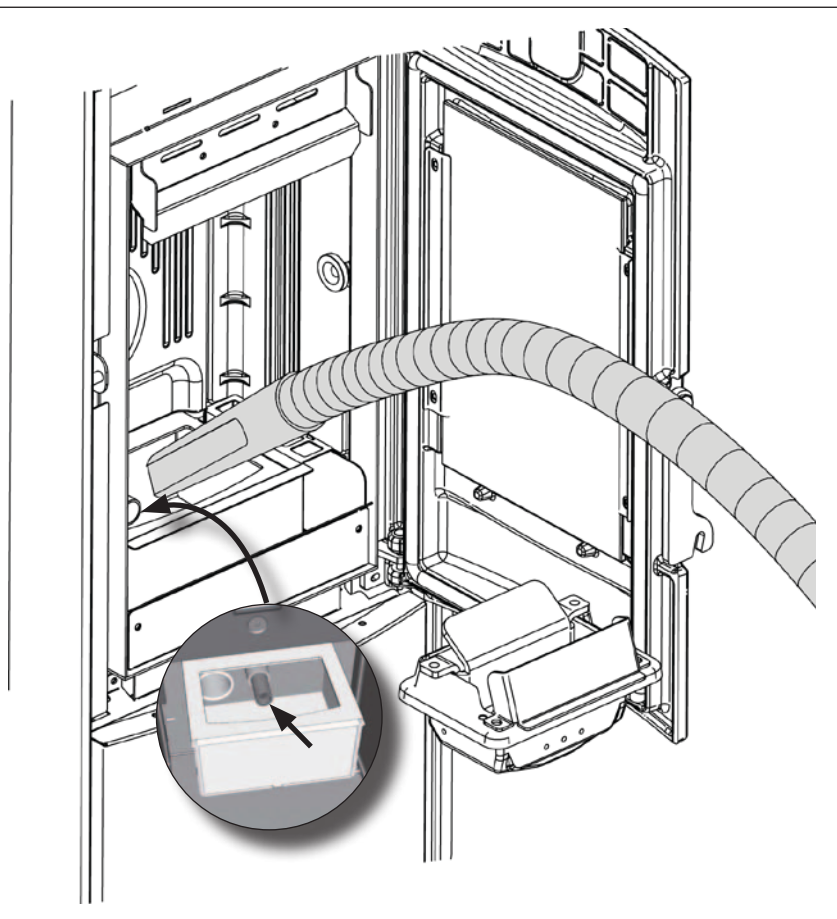

EVERY 3 DAYS

ASH DRAWER:

- ♦ Remove the ash drawer and empty it into a dedicated container.

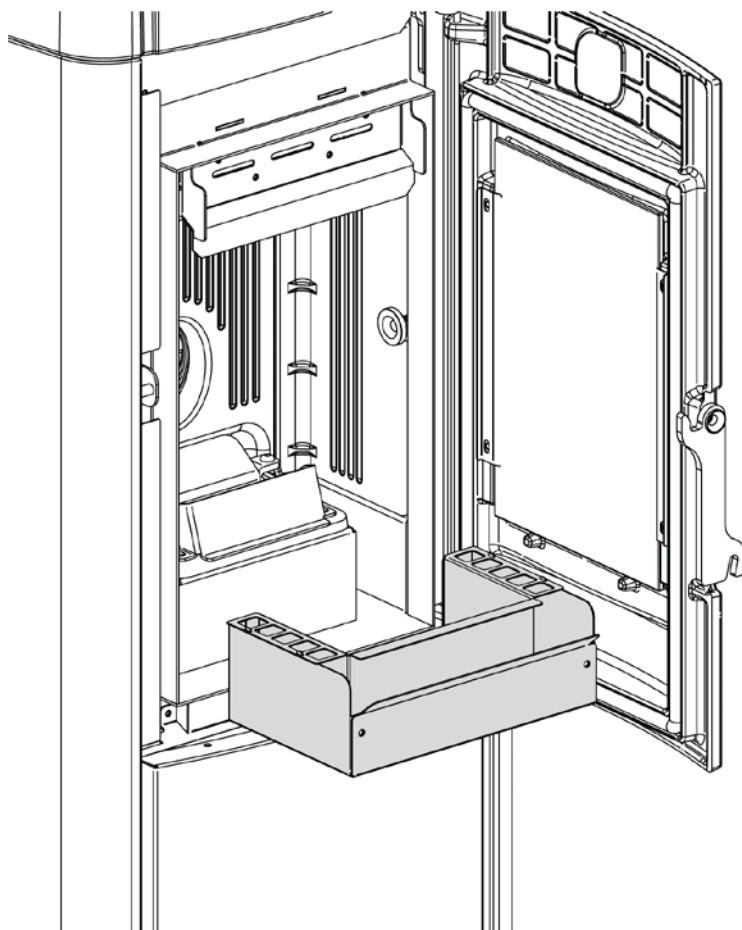

A CLEAN BURN POT GUARANTEES CORRECT OPERATION!



BY KEEPING THE BURN POT AND ITS HOLES CONSTANTLY CLEAN AND FREE OF COMBUSTION RESIDUE, EXCELLENT COMBUSTION IS GUARANTEED OVERTIME, THUS PREVENTING ANY GENERATOR MALFUNCTIONS THAT MAY REQUIRE TECHNICAL ASSISTANCE.

THE "EASY SETUP" FUNCTION IN THE USER MENU CAN BE USED TO ADAPT COMBUSTION TO SPECIFIC NEEDS.

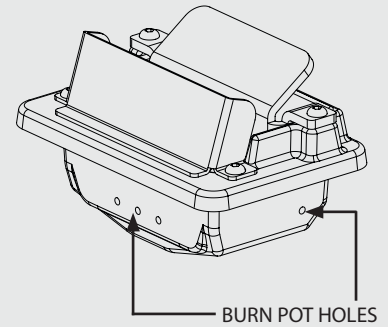

TO FIND OUT WHERE YOUR NEAREST SERVICE CENTRE IS, CONTACT YOUR DEALER OR GO TO THE WEBSITE:
WWW.LANORDICA-EXTRAFLAME.COM

ROUTINE MAINTENANCE PERFORMED BY QUALIFIED TECHNICIANS

Routine maintenance must be performed at least once a year.

Given the generator uses pellets as solid fuel, it requires annual routine maintenance, which must be performed by a **Qualified technician, using only original spare parts.**

Failure to comply may jeopardise the safety of the appliance and make the warranty null and void.

Respecting the frequencies of cleaning reserved for the user described in the use and maintenance manual, the generator is guaranteed correct combustion over time, preventing any anomalies and/or malfunctioning that could require more interventions of the technician. Requests for routine maintenance are not contemplated in the product warranty.

GASKETS: PELLET HOPPER COVER, DOOR, ASH DRAWER AND BURN POT

The gaskets ensure the stove is properly sealed consequently works properly.

They must be controlled periodically. They must be replaced immediately if they are worn or damaged.

These operations must be carried out by a qualified technician.

CLEANING THE FLUE GAS COMPARTMENT

The flue gas compartment should be cleaned every two months or whenever necessary and at the end of the season.

CONNECTION TO THE FLUE

Annually, or in any case each time the fumes exhaust pipe needs to be aspirated and cleaned. If there are horizontal sections, the residue must be removed to prevent it from obstructing the flow of fumes.

DECOMMISSIONING (END OF SEASON)

At the end of each season, before turning the stove off, it is advisable to empty the pellet hopper out completely, removing any pellet residue and dust with a vacuum cleaner.

We also recommend disconnecting the generator from the mains and, for added safety especially when children are present, remove the power cable.

Routine maintenance must be performed at least once a year.

TO FIND OUT WHERE YOUR NEAREST SERVICE CENTRE IS, CONTACT YOUR DEALER OR GO TO THE WEBSITE:
WWW.LANORDICA-EXTRAFLAME.COM

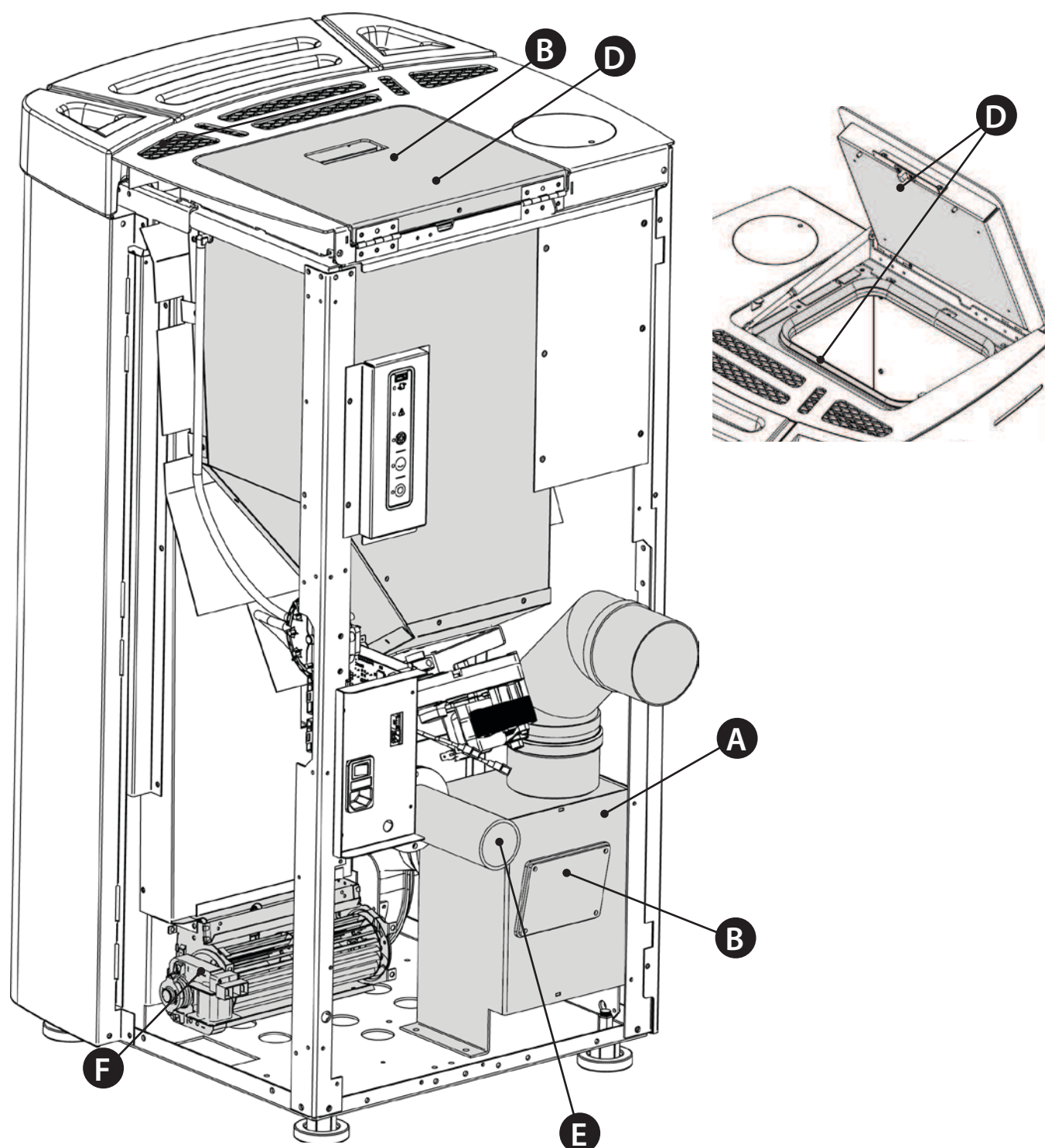

THE IMAGES ARE FOR ILLUSTRATIVE PURPOSES.

A	Fumes motor (disassembly and cleaning and fumes and "T" pipes), new silicone in the specified points
B	Gaskets, pellet hopper, inspections, ash drawer and door (replace and apply silicone where indicated)
C	Combustion chamber and heat exchanger (full cleaning) including ignition plug pipe
D	Hopper (complete emptying and cleaning) and check gasket.
E	Check air inlet pipe and check/clean mechanical pressure switch.
F	Dismantling of ambient air fan and removal of dust and pellet residue.

TO FIND OUT WHERE YOUR NEAREST SERVICE CENTRE IS, CONTACT YOUR DEALER OR GO TO THE WEBSITE:
WWW.LANORDICA-EXTRAFLAME.COM

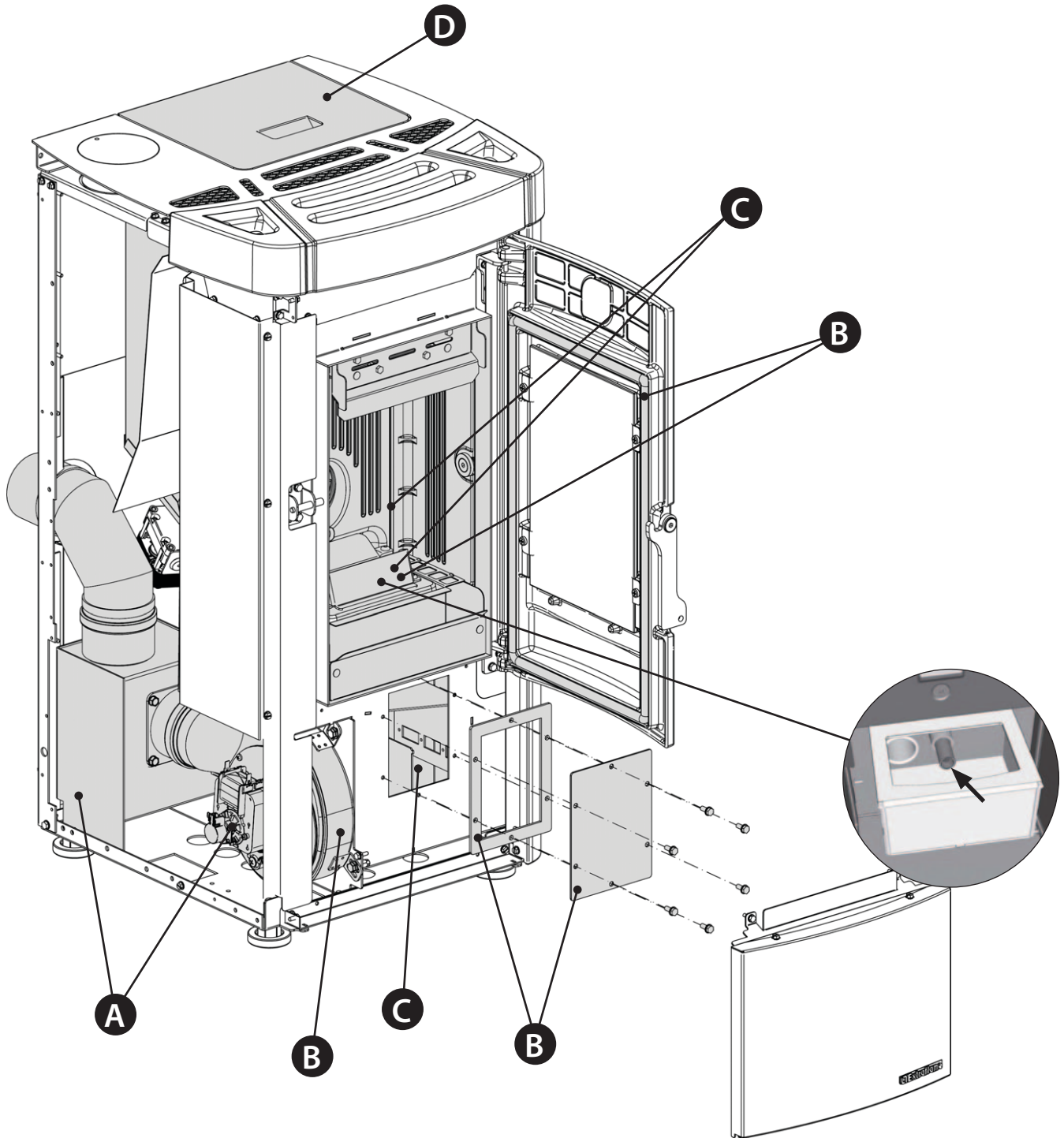

THE IMAGES ARE FOR ILLUSTRATIVE PURPOSES.

A	Fumes motor (disassembly and cleaning and fumes and "T" pipes), new silicone in the specified points
B	Gaskets, pellet hopper, inspections, ash drawer and door (replace and apply silicone where indicated)
C	Combustion chamber and heat exchanger (full cleaning) including ignition-plug pipe
D	Hopper (complete emptying and cleaning) and check gasket.
E	Check air inlet pipe and check/clean mechanical pressure switch.
F	Dismantling of ambient air fan and removal of dust and pellet residue.

READINGS

DISPLAY	REASON
OFF	Generator off
START	The start-up phase is in progress
PELLET LOADING	Continuous pellet loading is in progress during the ignition phase
IGNITION	The ignition phase is in progress
PREPARATION	The preparation phase is in progress
WORK	The normal work phase is in progress
MODULATION	The generator is working at minimum level
FINAL CLEANING	The final cleaning is in progress
STAND-BY	Generator off waiting for re-ignition due to the thermostat.
COOLING STAND-BY	A new ignition is attempted when the generator has just been switched off. When the generator switches off, wait for the fumes motor to completely shut down, then clean the burn pot. The generator can only be re-ignited after these operations have been performed.
BLACK OUT STAND-BY	The generator is cooling down after a power cut. Once cooling is complete it will automatically re-start
AUTO BLOW	Automatic blowing is active
SERVICE	When this message appears, contact the technician authorised to perform routine maintenance on the appliance. If cleaning is not performed, the message will appear at every start-up without interrupting normal stove operation.

ALARMS

DISPLAY	EXPLANATION	SOLUTION
	Indicates the presence of an alarm.	On: indicates the presence of an alarm. The alarm can only be reset if the fumes motor has stopped and 15 minutes have passed since the alarm was displayed, by pressing key 1 for 3 seconds.
FUMES MOTOR FAULT	Fumes motor fault	Contact after-sales service
FUMES PROBE	Fumes probe fault.	Contact after-sales service
HOT FUMES	High fumes temperature	Check pellet loading (see "Easy setup"). If the problem cannot be solved, contact an authorised technician.
NO IGNITION	The pellet hopper is empty. Pellet loading calibration inadequate. Thermostat bulbs tripped.	Check for the presence of pellets in the hopper. Adjust the pellet flow (see "Easy setup"). Check the procedures described in the "Ignition" chapter. Check the bulb thermostats (see chapter on Rearming)
NO FLAME	The pellet hopper is empty. No pellet loading. The gear motor does not load pellets.	Check for the presence of pellets in the hopper. Adjust the pellet flow (see "Easy setup").
DEPR ALARM	The door is not closed correctly. The ash drawer is not closed correctly. The combustion chamber is dirty. The fumes exhaust pipe is blocked/dirty	Check hermetic door closure. Check hermetic closure of the ash drawer. Check cleanliness of the fumes exhaust pipe and the combustion chamber.
NO IGNITION - BLACK OUT	No electrical current during the ignition phase.	Place the stove into "off" mode using key 1 and repeat the steps described in the "Ignition" chapter. Other restoration steps must be performed by an authorised technician.
COMMAND AUGER ALARM	Abnormal pellet loading.	Contact after-sales centre

GUARANTEE TERMS

1. Extraflame S.p.A. products are guaranteed, within the European community, for 24 months from the date of purchase. Purchase has to be proved by means of a valid fiscal document issued by the seller (receipt, invoice or shipment document) identifying the purchased product and its purchase and/or delivery date.

WARNING: *This conventional guarantee does not replace the guarantee regulated by the European legislation on consumer rights.*

The conventional guarantee is only applicable to the Italian region and to those areas, within the European Community, where the Authorised Technical Assistance Centres are active (see the www.lanordica-extraflame.com website)

It is also limited to the state of residence of the consumer, which must coincide with the premises and/or registered office of the seller of the Extraflame S.p.A. product

These regulations do not apply if the product is purchased within commercial, entrepreneurial, or professional circumstances. In these cases the product guarantee will be limited to a period of 12 months from the date of purchase.

ITALIAN GUARANTEE

What must be done if there is a product malfunction:

Consult the instructions manual to make sure the malfunction cannot be solved by using the product correctly. Make sure the malfunction is included in those covered by the guarantee; otherwise the cost of the intervention will be borne entirely by the consumer. When requesting the intervention of the Assistance service at the Authorised Assistance Centre, always specify: - type of malfunction - model of the appliance - complete address - phone number

EUROPEAN GUARANTEE

What must be done if there is a product malfunction:

Consult the instructions manual to make sure the malfunction cannot be solved by using the product correctly. Make sure the malfunction is included in those covered by the guarantee; otherwise the cost of the intervention will be borne entirely by the consumer. Request the intervention of the Assistance service or the address of the Authorised Technical Assistance Centre to the seller; always specify: type of malfunction, model of the appliance, complete address and phone number

If the malfunction arises in the first 6 months of the product's life, the consumer has the right to have the product repaired with no expense. From the seventh to the twenty-fourth month, if a malfunction arises, the consumer will bear the cost of the call, while the seller will pay for the manpower and for any spare parts used.

2. If the malfunction is linked to external events and/or conditions such as, including but not limited to, insufficient capacity of the systems; wrong installation and/or maintenance by the personnel which hasn't got the skills prescribed by the laws of the country of residence of the consumer; negligence; inability to use the product and wrong maintenance by the consumer, with respect to what is reported and recommended by the instructions manual of the product, which is part of the sales contract, this guarantee will be void.

Damage to the product that cannot be related to manufacturing defects are also not included in this guarantee. Similarly are excluded defects related to incorrect operation of the flue, according to the legislation in force in the country at the moment of purchase. Other exclusions include all product defects due to carelessness, accidental breakdown, tampering and/or damage during transport (scratches, dents, etc.), interventions carried out by unauthorised personnel and further damage caused by incorrect interventions by the consumer trying to arrange the initial malfunction.

The following consumables are excluded by the guarantee: gaskets, ceramic or tempered glasses, cast iron grilles or coatings, refractory materials (e.g. Nordiker or others), painted, chrome-plated or golden parts, majolica ware, handles, the brazier and its related components. For Idro products the heat exchanger is not covered by the guarantee if a suitable condensation-proof circuit is not set up to ensure a return temperature of the device of at least 55°C. The guarantee excludes all the external components on which the consumer can directly operate during use and/or maintenance or that can be subject to wear and/or rust and stains on steel due to aggressive detergents.

If malfunctions are signalled which are not later confirmed during check by an authorised technician, the cost of the intervention will be borne entirely by the consumer.

3. If it is not possible to restore product conformity by repairing it, the product/component will be replaced, the guarantee expiration date and conditions will remain the same established when the product/component to be replaced has been purchased.

4. Extraflame S.p.A. cannot be held liable for injury or damage which may - either directly or indirectly - be caused to persons, animals and property ensuing from failure to observe all the instructions provided in the relevant instruction manual and the warnings regarding installation, use and maintenance of the product, that can also be downloaded on the website.

5. Interventions for adjusting and/or regulating the product for the type of fuel or other reasons are excluded by the guarantee.

6. If the product is repaired in one of the Authorised Technical Assistance Centres indicated by Extraflame S.p.A. and if the product is replaced, transport will be free of charge. If the technician can repair the product at the user's place of residence and they refuse, transport to the workshop and redelivery will be paid by the consumer.

7. After the 24 months of the guarantee have elapsed any repair intervention cost will be completely borne by the consumer.

8. In the case of disputes the only competent court is that of the Extraflame S.p.A. registered office - (Vicenza-Italy)

ADDITIONAL WARNINGS

- ◆ Only use the fuel recommended by the manufacturer. The product must not be used as an incinerator.
 - ◆ Do not use the product as a ladder or supporting structure.
 - ◆ Do not place laundry on the product to dry it. Any clothes-horse or similar objects must be kept at due distance from the product.
- Danger of fire or damage to the coating.
- ◆ The user is fully liable for any incorrect use of the product. The manufacturer bears no civil or criminal liability for incorrect use.
 - ◆ Unauthorised tampering of any nature or replacement of spare parts of the product with non-original parts may endanger the operator and the manufacturer bears no civil or criminal liability for this.
 - ◆ Large parts of the surface of the product can get very hot (door, handle, glass, smoke outlet pipes, etc.). Please therefore avoid coming into contact with these parts without wearing suitable protective clothing or using appropriate measures, such as heat protective gloves.
 - ◆ DO NOT use the product with the door open or if the glass is broken.
 - ◆ The product must be electrically connected to a system equipped with an operational earthing system.
 - ◆ Turn off the product in the event of a failure or malfunctioning.
 - ◆ Unburned pellets that build up in the burner following each failed start-up must be removed before attempting to start up the product again. Make sure that the burner is clean and correctly positioned before starting it up again.
 - ◆ Do not wash the product with water. Water may penetrate into the unit and cause faults in the electrical insulation. This can cause electric shocks.
 - ◆ Installations not complying with the regulations in force, as well as incorrect use and failure to comply with the maintenance scheduled by the manufacturer, will invalidate the guarantee.

Lined writing area consisting of multiple horizontal lines for text entry.

Extraflame®

Riscaldamento a Pellet

Extraflame S.p.A. Via Dell'Artigianato, 12 36030 - MONTECCHIO PRECALCINO (VI) - ITALY
☎ +39.0445.865911 - 📠 +39.0445.865912 - ✉ info@extraflame.it - 🌐 www.lanordica-extraflame.com

MADE IN ITALY
design & production

*TO FIND THE SERVICE CENTRE NEAREST TO YOU
CONTACT YOUR DEALER OR CONSULT
THE SITE WWW.LANORDICA-EXTRAFLAME.COM*

The manufacturer reserves the right to vary the characteristics and the data reported in this pamphlet at any moment and without notice, in order to improve its products.
This manual, therefore, cannot be regarded as a contract towards other parties.