

Extrablame®

Riscaldamento a Pellet



UK

PELLET STOVES USER MANUAL

MADE IN ITALY
design & production

LUISELLA

004276847 - REV001



ATTENTION



**SURFACES CAN BECOME VERY HOT!
ALWAYS USE PROTECTIVE GLOVES!**

During combustion, thermal energy is released that significantly increases the heat of surfaces, doors, handles, controls, glass, exhaust pipes, and even the front of the appliance. Avoid contact with those elements if not wearing protective clothing (protective gloves included). Make sure children are aware of the danger and keep them away from the stove during operation.

ENGLISH	5
WARNINGS	5
SAFETY	5
ROUTINE MAINTENANCE	6
INSTALLATION	7
GENERAL.....	7
DETAILS OF LUISELLA	9
SPACERS.....	10
FUSE.....	10
STOVE POSITIONING	11
NOTE FOR CORRECT OPERATION	11
PELLET HOPPER - PRESSURISED CLOSURE	11
PELLETS AND FEEDING	12
THE DISPLAY DESCRIPTION OF BASIC COMMANDS AND SYMBOLS	13
DISPLAY ICONS KEY.....	13
GENERAL MENU	14
BASIC INSTRUCTIONS.....	14
REMOTE CONTROL	15
BATTERY TYPE AND REPLACEMENT.....	15
COMMISSIONING SETTINGS	16
DATE (DATE).....	16
DAY (DATE).....	16
TIME (TIME).....	16
LNG (LANGUAGE).....	16
C-F (CELSIUS/FAHRENHEIT).....	16
OPERATION AND LOGIC	17
AIR (VENTILATION)	18
EASY (PELLET CALIBRATION)	18
STAT (STATUS)	19
CRNO (CHRONO)	19
ABIL (ENABLE).....	19
PRG 1-4 (PROGRAMMING 1-4).....	19
SET (SETTINGS)	22
STBY (STAND-BY).....	22
OPERATION WITH SUPPLEMENTARY THERMOSTAT (OPTIONAL).....	22
DELT (DELTA-T).....	22
RES (RESET).....	23
ADDITIONAL FUNCTIONS	23
FIRST LOAD.....	23
DELAY SWITCH-OFF.....	23
SUPPLEMENTARY THERMOSTAT INSTALLATION (OPTIONAL).....	23
CLEANING AND MAINTENANCE	24
MAINTENANCE	24
PERIODIC CLEANING BY THE USER.....	24
BURN POT DETAIL.....	27
ROUTINE MAINTENANCE PERFORMED BY QUALIFIED TECHNICIANS	28
DECOMMISSIONING (END OF SEASON).....	28
DISPLAYS	31
ALARMS	31
GUARANTEE TERMS	32

ATTENZIONE !
DURANTE LA MOVIMENTAZIONE DELLA
MACCHINA, FARE PARTICOLARE
ATTENZIONE AI COMPONENTI IN DETTA-
GLIO!

WARNING!
DURING THE HANDLING OF THE MACHINE,
PAY ACCURATE ATTENTION TO THE COM-
POONENTS IN DETAIL.

ATTENTION!
PENDANT LE DEPLACEMENT DE LA MACHI-
NE, FAIRE TRES
ATTENTION AUX COMPOSANTS EN DETAIL.

WARNUNG!
BEI DER HANDHABUNG DER MASCHINE
BEACHTEN SIE DIE KOMPONENTEN
IM DETAIL.

ATENCION!
DURANTE EL DESPLAZAMIENTO DE LA MA-
QUINA, TENER
MUCHO CUIDADO A LOS COMPONENTES
EN DETALLE.

ATENÇÃO !
DURANTE A MOVIMENTAÇÃO DA MÁQUI-
NA, PRESTAR ESPECIAL
ATENÇÃO AOS COMPONENTES EM DE-
TALHE!

OPGELET!
LET TIJDENS DE VERPLAATSING VAN DE
MACHINE IN HET BIJZONDER OP VOOR DE
ONDERDELEN IN HET DETAIL!

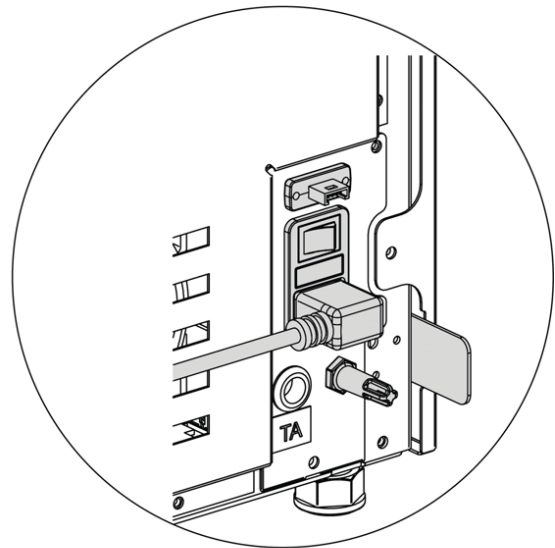
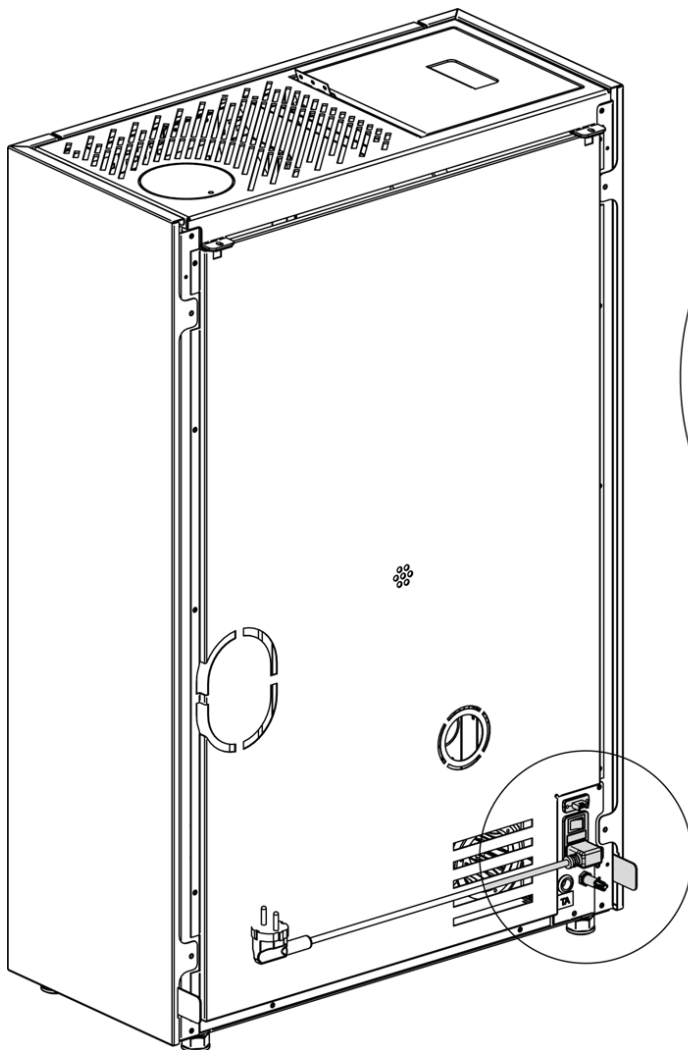

HANDLE WITH CARE

We thank you for having chosen our company; our product is a great heating solution developed from the most advanced technology with top quality machining and modern design, aimed at making you enjoy the fantastic sensation that the heat of a flame gives, in complete safety.

WARNINGS

This instructions manual is an integral part of the product: make sure that it always accompanies the appliance, even if transferred to another owner or user, or if transferred to another place. If it is damaged or lost, request another copy from the area technician. This product is intended for the use for which it has been expressly designed. The manufacturer is exempt from any liability, contractual and extracontractual, for injury/damage caused to persons/animals and objects, due to installation, adjustment and maintenance errors and improper use.

Installation must be performed by qualified staff, which assumes complete responsibility for the definitive installation and consequent good functioning of the product installed. One must also bear in mind all laws and national, regional, provincial and town council Standards present in the country in which the appliance has been installed, as well as the instructions contained in this manual.

The Manufacturer cannot be held responsible for the failure to comply with such precautions.

After removing the packaging, ensure that the content is intact and complete. Otherwise, contact the dealer where the appliance was purchased.

All electric components that make up the product must be replaced with original spare parts exclusively by an authorised after-sales centre, thus guaranteeing correct functioning.

SAFETY

- ◆ **THE APPLIANCE MAY BE USED BY CHILDREN 8 YEARS OF AGE OR OLDER AND INDIVIDUALS WITH REDUCED PHYSICAL, SENSORY, OR MENTAL CAPACITIES OR WITHOUT EXPERIENCE OR THE NECESSARY KNOWLEDGE, PROVIDED THAT THEY ARE SUPERVISED OR HAVE RECEIVED INSTRUCTIONS ON SAFE USE OF THE APPLIANCE AND THAT THEY UNDERSTAND THE INHERENT DANGERS.**
- ◆ **THE GENERATOR MUST NOT BE USED BY PERSONS (INCLUDING CHILDREN) WITH REDUCED PHYSICAL, SENSORY AND MENTAL CAPACITIES OR WHO ARE UNSKILLED PERSONS, UNLESS THEY ARE SUPERVISED AND TRAINED REGARDING USE OF THE APPLIANCE BY A PERSON RESPONSIBLE FOR THEIR SAFETY.**
- ◆ **THE CLEANING AND MAINTENANCE REQUIRED BY THE USER MUST NOT BE PERFORMED BY CHILDREN WITHOUT SUPERVISION.**
- ◆ **CHILDREN MUST BE CHECKED TO ENSURE THAT THEY DO NOT PLAY WITH THE APPLIANCE.**
- ◆ **DO NOT TOUCH THE GENERATOR WHEN YOU ARE BAREFOOT OR WHEN PARTS OF THE BODY ARE WET OR DAMP.**
- ◆ **THE SAFETY AND ADJUSTMENT DEVICES MUST NOT BE MODIFIED WITHOUT THE AUTHORISATION OR INDICATIONS OF THE MANUFACTURER.**
- ◆ **DO NOT PULL, REMOVE, TWIST THE ELECTRICAL CABLES COMING OUT OF THE PRODUCT EVEN IF IT IS DISCONNECTED FROM THE MAINS.**
- ◆ **IT IS ADVISED TO POSITION THE POWER SUPPLY CABLE SO THAT IT DOES NOT COME INTO CONTACT WITH HOT PARTS OF THE APPLIANCE.**
- ◆ **THE POWER SUPPLY PLUG MUST BE ACCESSIBLE AFTER INSTALLATION.**
- ◆ **DO NOT CLOSE OR REDUCE THE DIMENSIONS OF THE AIRING VENTS IN THE PLACE OF INSTALLATION. THE AIRING VENTS ARE ESSENTIAL FOR CORRECT COMBUSTION.**

- ◆ DO NOT LEAVE THE PACKAGING ELEMENTS WITHIN REACH OF CHILDREN OR UNASSISTED DISABLED PERSONS.
- ◆ THE HEARTH DOOR MUST ALWAYS BE CLOSED DURING NORMAL FUNCTIONING OF THE PRODUCT.
- ◆ WHEN THE APPLIANCE IS FUNCTIONING AND HOT TO THE TOUCH, ESPECIALLY ALL EXTERNAL SURFACES, ATTENTION MUST BE PAID
- ◆ CHECK FOR THE PRESENCE OF ANY OBSTRUCTIONS BEFORE SWITCHING THE APPLIANCE ON FOLLOWING A PROLONGED PERIOD OF INACTIVITY.
- ◆ THE GENERATOR HAS BEEN DESIGNED TO FUNCTION IN ANY CLIMATIC CONDITION. IN PARTICULARLY ADVERSE CONDITIONS (STRONG WIND, FREEZING) SAFETY SYSTEMS MAY INTERVENE THAT SWITCH THE GENERATOR OFF. IF THIS OCCURS, CONTACT THE TECHNICAL AFTER-SALES SERVICE AND ALWAYS DISABLE THE SAFETY SYSTEMS.
- ◆ IN THE EVENT THE FLUE CATCHES FIRE, USE SUITABLE SYSTEMS FOR SUFFOCATING THE FLAMES OR REQUEST HELP FROM THE FIRE BRIGADE.
- ◆ THIS APPLIANCE MUST NOT BE USED TO BURN WASTE
- ◆ DO NOT USE ANY FLAMMABLE LIQUIDS FOR IGNITION
- ◆ DURING THE FILLING PHASE DO NOT PUT THE BAG OF PELLETS TO INTO CONTACT WITH THE PRODUCT
- ◆ THE MAJOLICAS ARE TOP QUALITY ARTISAN PRODUCTS AND AS SUCH CAN HAVE MICRO-DOTS, CRACKLES AND CHROMATIC IMPERFECTIONS. THESE FEATURES HIGHLIGHT THEIR VALUABLE NATURE. DUE TO THEIR DIFFERENT DILATION COEFFICIENT, THEY PRODUCE CRACKLING, WHICH DEMONSTRATE THEIR EFFECTIVE AUTHENTICITY. TO CLEAN THE MAJOLICAS, IT IS RECOMMENDED TO USE A SOFT, DRY CLOTH. IF A DETERGENT OR LIQUID IS USED, THE LATTER COULD PENETRATE INSIDE THE CRACKLES, HIGHLIGHTING THEM.

ROUTINE MAINTENANCE

Based on Decree 22 January 2008 n°37 art.2, routine maintenance means interventions aimed at reducing degradation due to normal use, as well as dealing with accidental events entailing the need of first interventions, which however do not modify the structure of the system upon which one is intervening or its intended use according to the requirements laid down by the technical standards in force and by the manufacturer's use and maintenance manual.

INSTALLATION

GENERAL

The flue gas exhaust and hydraulic connections must be carried out by qualified personnel who must issue installation conformity documentation compliant with national standards.

The installer must provide the owner or person acting for him, according to the legislation in force, with the declaration of conformity, supplied with:

- 1) the use and maintenance manual of the appliance and of the system components (such as for example, the smoke ducts, chimney, etc.);
- 2) photocopy or photograph of the chimney plaque;
- 3) system booklet (where applicable).

The installer must ask to be issued with a receipt stating that the documentation has been provided, and must keep it with a copy of the technical documentation relating to the installation.

For installation in a condominium, prior approval from the condominium's administrator must be requested.

Where required, check the exhaust gas emissions after installation. Should a sampling point be installed, it must be airtight.

COMPATIBILITY

Installation in premises with fire hazards is forbidden. Installation in residential premises (except for sealed operation appliances) is also forbidden:

- ♦ in which there are liquid fuel-operated appliances with continuous or intermittent operation, which draw the combustion air in the room in which they are installed, or
- ♦ in which there are type B gas appliances intended for room heating, with or without production of domestic hot water and in adjacent and adjoining premises, or
- ♦ in which, in any case, the depression measured during installation between the internal and external environment is greater than 4 Pa

INSTALLATIONS IN BATHROOMS, BEDROOMS AND STUDIO FLATS

Installation in bathrooms, bedrooms and studio flats is only allowed for sealed or closed hearth appliances with ducted combustion air taken from the outside.

POSITIONING AND SAFETY DISTANCES

The support surfaces and/or points must have a suitable capacity to bear the overall weight of the appliance, accessories and coverings. If the floor is made of a combustible material, we recommend using a non-combustible material to protect the front part from any burnt material which might fall during routine cleaning operations.

The generator must be level to function properly.

The adjacent, side and rear walls and the supporting surface must be made of non-combustible material. Installation adjacent to combustible or heat sensitive materials is allowed as long as there is a suitable safety distance in between, which for pellet stoves is:

REFERENCES	INFLAMMABLE OBJECTS	NON-INFLAMMABLE OBJECTS
A	200 mm	100 mm
B	1500 mm	750 mm
C	200 mm	100 mm

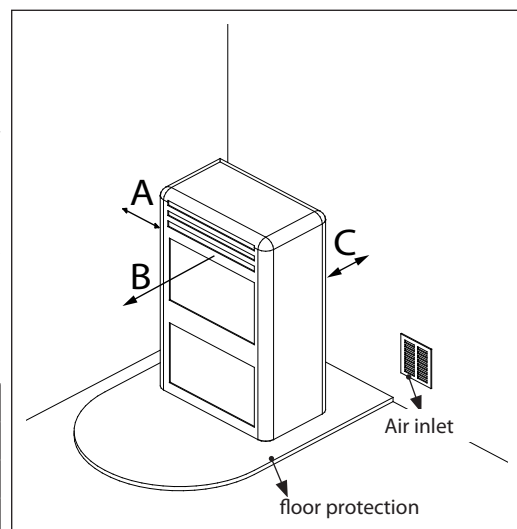

INSTALLING INSERTS

When installing inserts, access must be prevented to the internal parts of the appliance and it must not be possible to access live parts during extraction operations.

Any wiring, for example the power cable or room probe, must be positioned so as not to be damaged during movement of the insert and must not come into contact with hot parts.

VENTILATION AND AERATION OF THE INSTALLATION PREMISES

Ventilation is deemed sufficient when the room is equipped with air inlets according to the table:

Appliance categories	Reference standard	Percentage of the net opening section with respect to the appliance fumes outlet section	Minimum net opening value of the ventilation duct
Pellet stoves	UNI EN 14785	-	80 cm ²
Boilers	UNI EN 303-5	50%	100 cm ²

In any case ventilation is deemed sufficient when the pressure difference between the external and internal environment is equal to or less than 4 Pa.

In the presence of type B gas appliances with intermittent operation not intended for heating, they must have their own aeration and/or ventilation opening.

The air inlets must meet the following requirements:

- ♦ they must be protected with grids, metal mesh, etc., but without reducing the net useful section;
- ♦ they must be made so as to make the maintenance operations possible;
- ♦ positioned so that they cannot be obstructed;

The clean and non-contaminated air flow can also be obtained from a room adjacent to that of installation (indirect aeration and ventilation), as long as the flow takes place freely through permanent openings communicating with the outside.

The adjacent room cannot be used as a garage, or to store combustible material or for any other activity with a fire hazard, bathroom, bedroom or common room of the building.

FLUE GAS EXHAUST

The heat generator works in depression and is equipped with an outlet fan for flue gas extraction. There must be a single exhaust system for the generator. Using a flue that is shared with other devices is not allowed.

The components of the flue gas exhaust system must be chosen in relation to the type of appliance to be installed in compliance with:

- ♦ UNI/TS 11278 in the event of metal chimneys, with particular attention to that stated in the specification;
- ♦ UNI EN 13063-1 and UNI EN 13063-2, UNI EN 1457, UNI EN 1806 in the event of non-metallic chimneys.
- ♦ The length of the horizontal section must be minimal and, in any case, no longer than 3 metres, with a minimum upward slope of 3%.
- ♦ There must not be more than 4 direction changes including the one due to the use of the "T" element.
- ♦ A "T" fitting with a condensation collection cap must be provided at the base of the vertical section.
- ♦ If the exhaust is not inserted in an existing flue, a vertical section with a windproof end piece is required (UNI 10683).
- ♦ The vertical duct can be inside or outside the building. If the smoke duct is inserted in an existing flue, it must be certified for solid fuel.
- ♦ If the smoke duct is outside the building, it must always be insulated.
- ♦ The smoke ducts must have at least one airtight inlet for flue gas sampling.
- ♦ All the sections of the flue gas duct must be accessible to inspection.
- ♦ Inspection openings must be provided for cleaning.
- ♦ If the generator has a fume temperature lower than 160°C+ ambient temperature caused by the high yield (contact technicians) it MUST be resistant to humidity.

CHIMNEY CAP

The chimney caps must meet the following requirements:

- ♦ they must have a useful outlet section no less than double that of the chimney/ducted system on which it is installed;
- ♦ they must be adapted in order to prevent the penetration of rain and snow in the chimney/ducted system;
- ♦ they must be built so that, in the event of winds coming from all directions and from any angle, the expulsion of combustion products is in any case ensured;

EXAMPLES OF CORRECT CONNECTION TO THE CHIMNEY

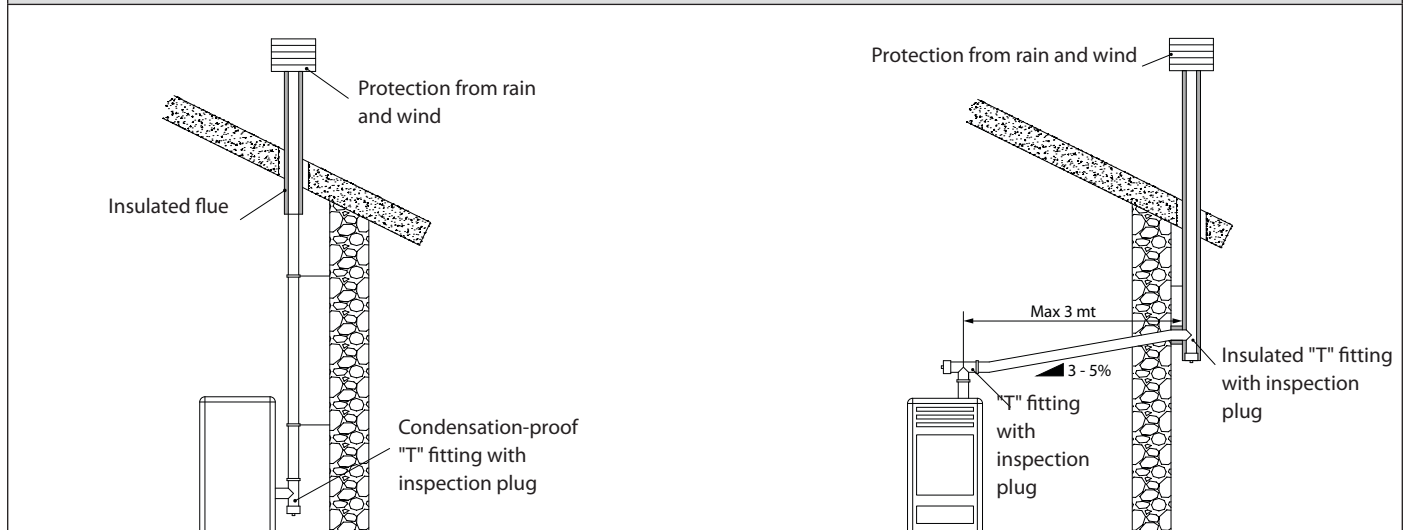

CONNECTION TO THE MAINS ELECTRIC SUPPLY

The generator is supplied with an electric power cable to be plugged into a 230V 50 Hz socket, possibly with a circuit breaker switch. The socket must be easily accessible.

The electrical system must be compliant with standards. The efficiency of the earthing circuit must be checked. Unsuitable earthing of the system can cause malfunctioning for which the manufacturer will not be held liable.

Power supply variations beyond 10% can cause faulty operation of the product.

DETAILS OF LUISELLA

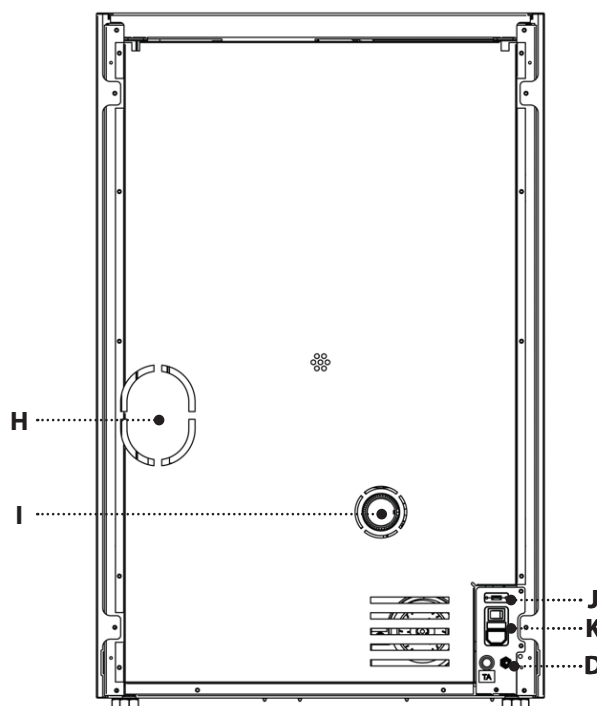
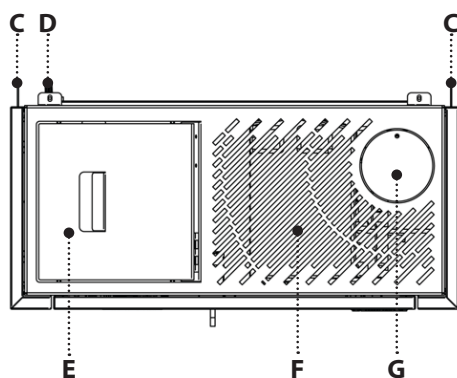
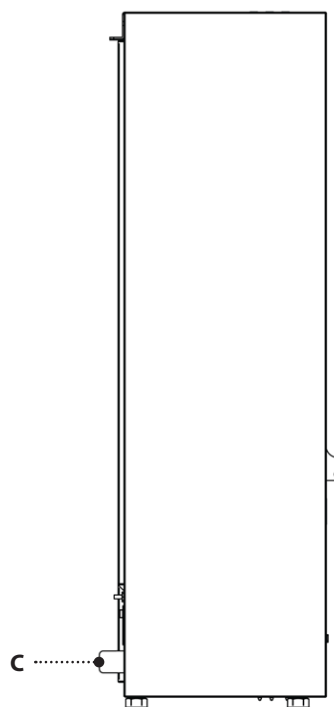
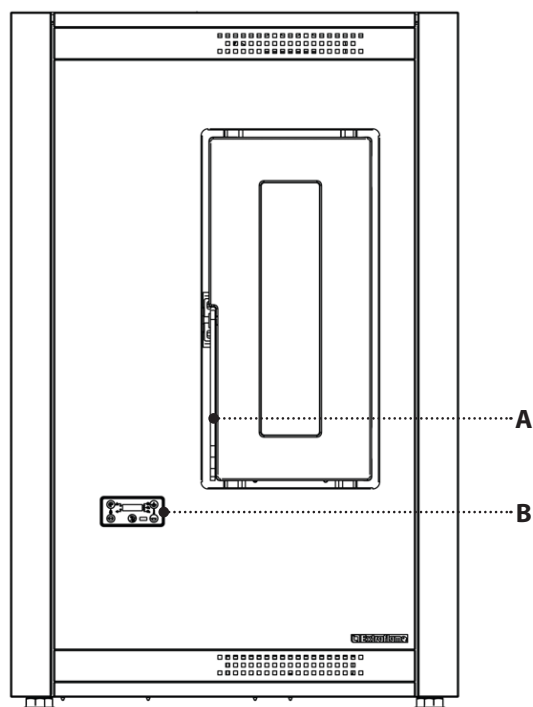

A	Access to combustion chamber	E	Pellet hopper pressurised closure	I	Combustive air input
B	Display	F	Room air outlet	j	Serial input
C	Spacer	G	Upper fumes exhaust	K	On/Off
D	Room sensor	H	Rear fumes exhaust		Fuse
					Power supply 230V

SPACERS

There are two spacers located on the rear of the machine which determine the minimum distance any support behind the stove. The spacers must not be removed.

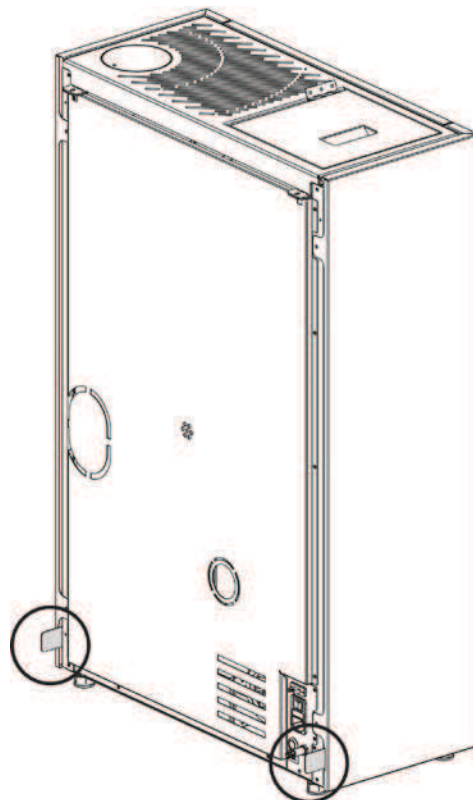
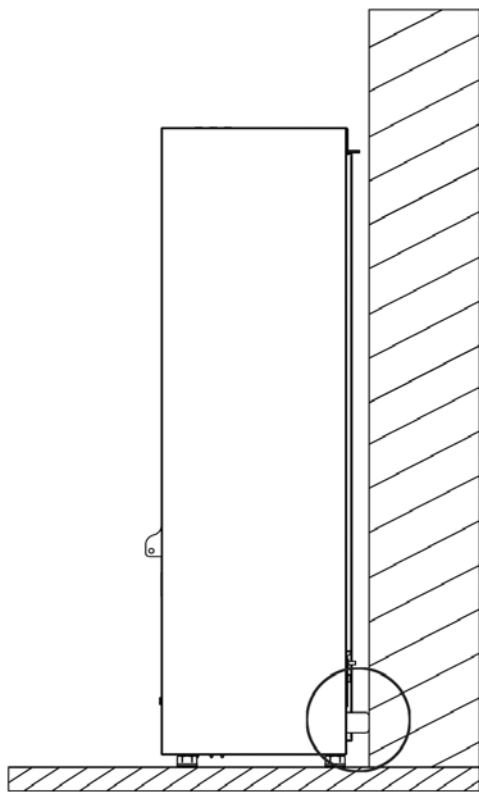

FUSE

If there is no power supply to the stove, check the state of the fuse located in the box between the stove switch and the power cable connection.

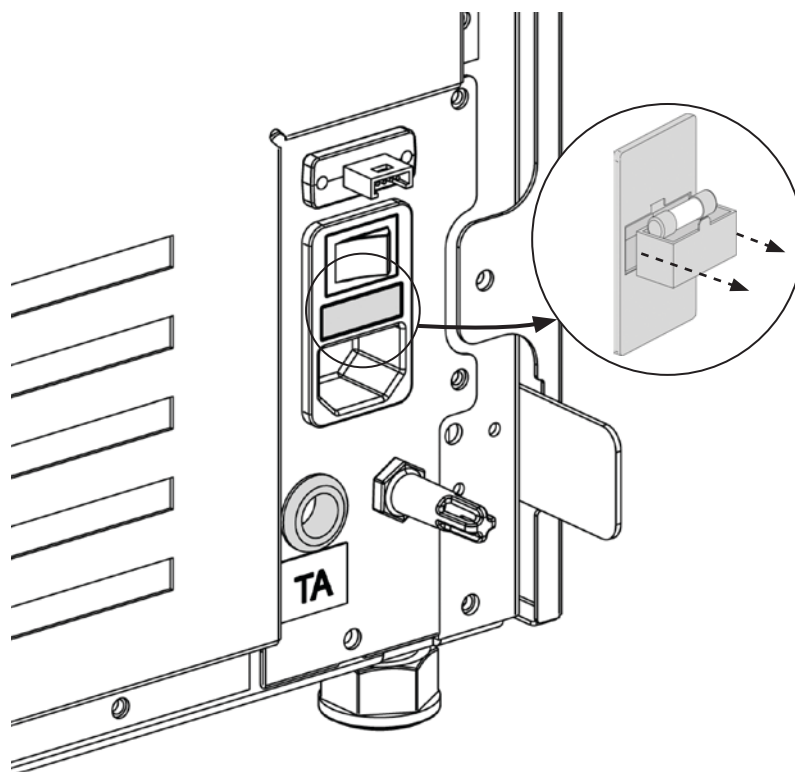

STOVE POSITIONING

To ensure the stove works correctly, it should always be positioned so that it is perfectly level, using a spirit level.

NOTE FOR CORRECT OPERATION

The following indications must be respected for correct pellet stove operation:

During stove operation, both the pellet hopper lid and the door must always be closed.

Failure to comply with the above during operation will cause the display to show the following:

"CLOSE HOPPER - STOVE DOOR"

This indication means that you have 60" to close the hatch/door and the pellet lid.

After 60 seconds, when the stove ignites, it will go to "DEPR ALARM" mode, while during normal operation the stove will go to "COOLING STAND BY" mode and then re-start automatically when the correct conditions are present (stove cold, etc.).

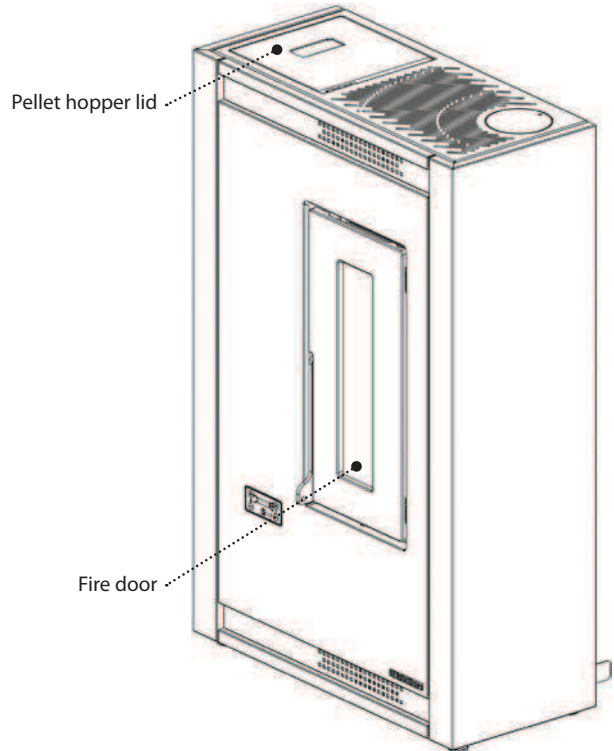

PELLET HOPPER - PRESSURISED CLOSURE

During stove operation, the pellet hopper lid must always be closed.

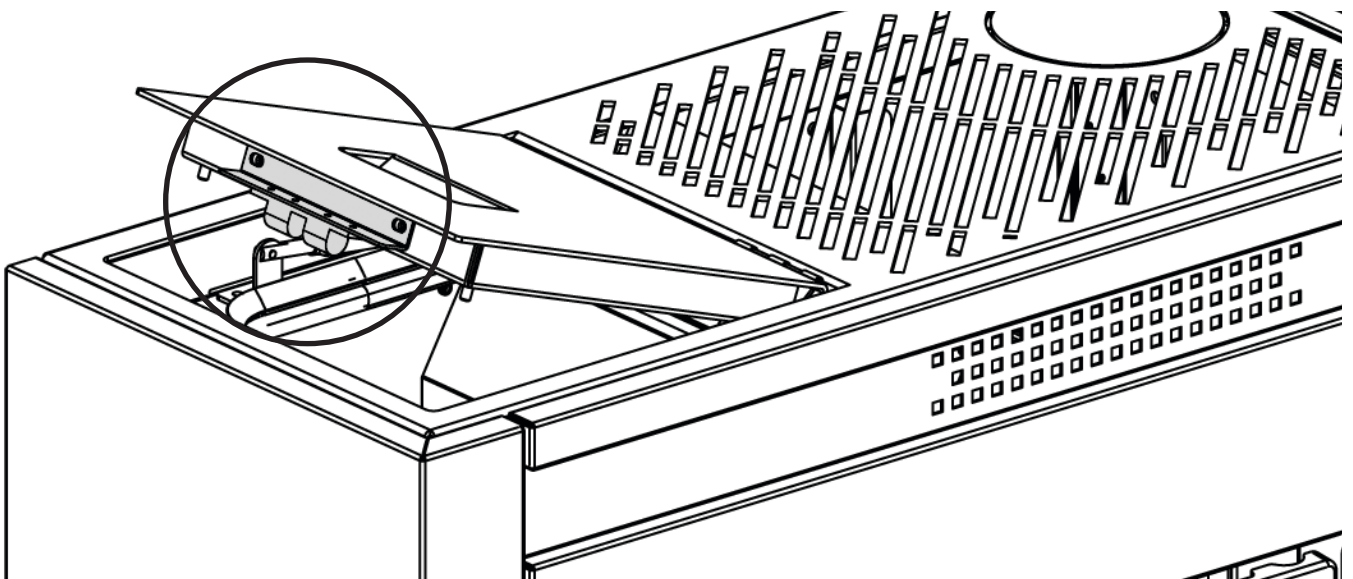

DO NOT PLACE THE BAG DIRECTLY ON THE STOVE WHEN LOADING THE HOPPER!
ALWAYS USE A SCOOP TO LOAD THE HOPPER. DO NOT RUB OR PLACE WEIGHTS ON THE HOPPER SEAL. KEEP THE HOPPER LID SEAL SUPPORT SURFACE CLEAN AT ALL TIMES. CHECK THE CONDITIONS OF THE SEAL FREQUENTLY. IF DAMAGED, CONTACT YOUR LOCAL AUTHORISED TECHNICIAN.

PELLETS AND FEEDING

Pellets are made by applying high pressure to sawdust, or wood waste products (not containing paint) from sawmills, carpentry and other activities related to processing and working with wood. Given that it does not use any glue to hold it together this type of fuel is completely environmentally friendly. In fact the compactness of the pellets over time is guaranteed by a natural substance found in the wood itself: wood coal. In addition to being an environmentally friendly fuel in that it pushes wood residues to the limits pellets also have technical advantages. While wood has a calorific value of 4.4kWh/kg. (with 15% humidity after around 18 months of seasoning) the calorific value of pellets is 5 kWh/kg. Pellet density is 650kg/m³ and the water content is equal to 8% of its weight. For this reason they do not require seasoning in order to arrive at a sufficiently adequate degree of heat yield.

The pellets used must comply with the characteristics described by the following standards:

- ◆ **EN PLUS - UNI EN 14961 - 2 (UNI EN ISO 17225-2) class A1 - A2**

The manufacturer always recommended using pellets with a diameter of 6 mm with its products.

PELLET STORAGE

In order to ensure problem-free combustion pellets must be stored in a dry place.
Open the tank lid and load the pellets using a scoop.

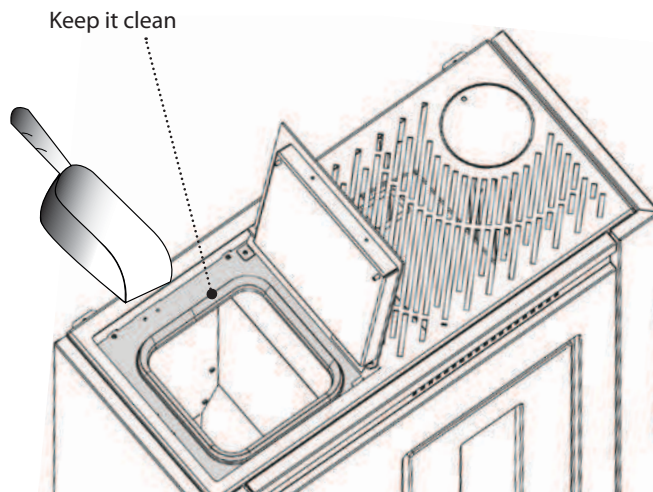

 **THE USE OF EXPIRED PELLETS OR ANY OTHER MATERIAL WILL AFFECT THE FUNCTIONALITY OF YOUR GENERATOR AND MAY LEAD TO THE TERMINATION OF THE WARRANTY AND CESSATION OF ANY ACCOMPANYING RESPONSIBILITY ON THE PART OF THE MANUFACTURER**

THE DISPLAY DESCRIPTION OF BASIC COMMANDS AND SYMBOLS

1	ON/OFF BUTTON
2	INCREASE SET POWER
3	DECREASE SET POWER
4	INCREASE SET THERMOSTAT
5	DECREASE SET THERMOSTAT

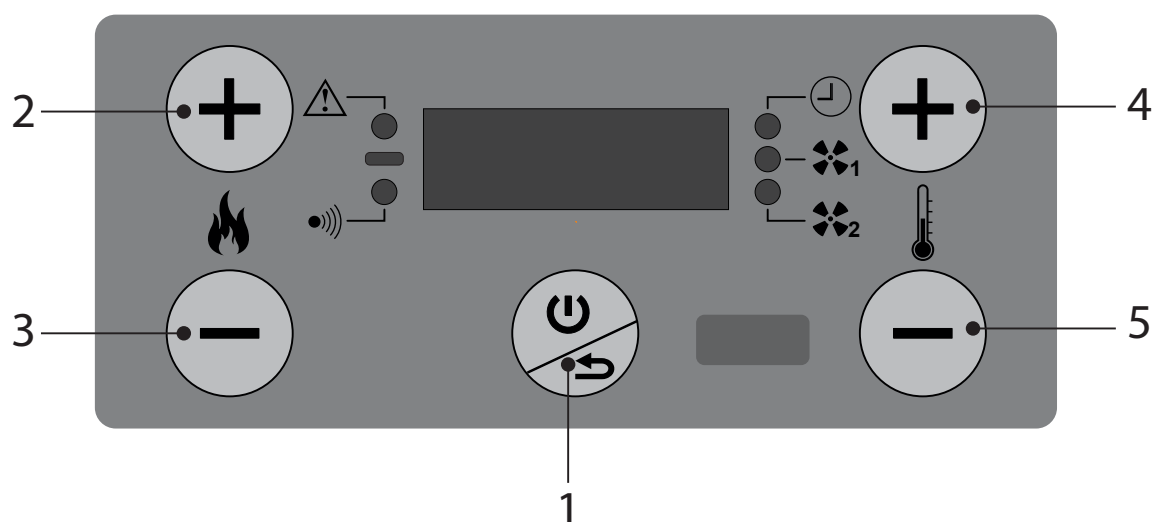

DISPLAY ICONS KEY

	Indicates the presence of an alarm. On: indicates the presence of an alarm. Off: indicates there are no alarms Flashing: fire door or pellet hopper open
	Indicates the set temperature status LED on: the stove is reaching the set temperature (room temperature still lower than set temperature) LED off: the stove has reached the set temperature
	Indicates communication by remote control LED on: communication received by multi-purpose remote control
	Indicates weekly programming operation Light on = weekly programming active Light off = weekly programming disabled Flashing light = "delayed switch-off" function enabled
	Indicates the tangential fan status Light off = motor deactivated Light on = motor activated
	Not used

GENERAL MENU

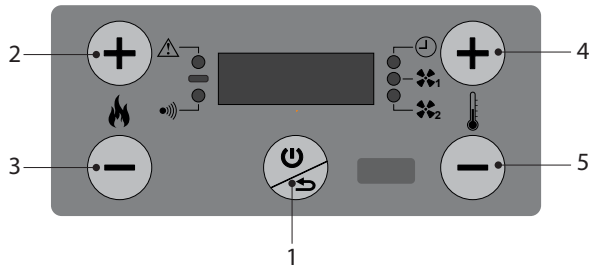

1	ON/OFF BUTTON - EXIT MENU
2	SCROLL UP - CONFIRM
3	SCROLL DOWN
4	PRESS AND HOLD TO ACCESS MENU - ACCESS SELECTED MENU - INCREASE VALUE
5	DECREASE VALUE

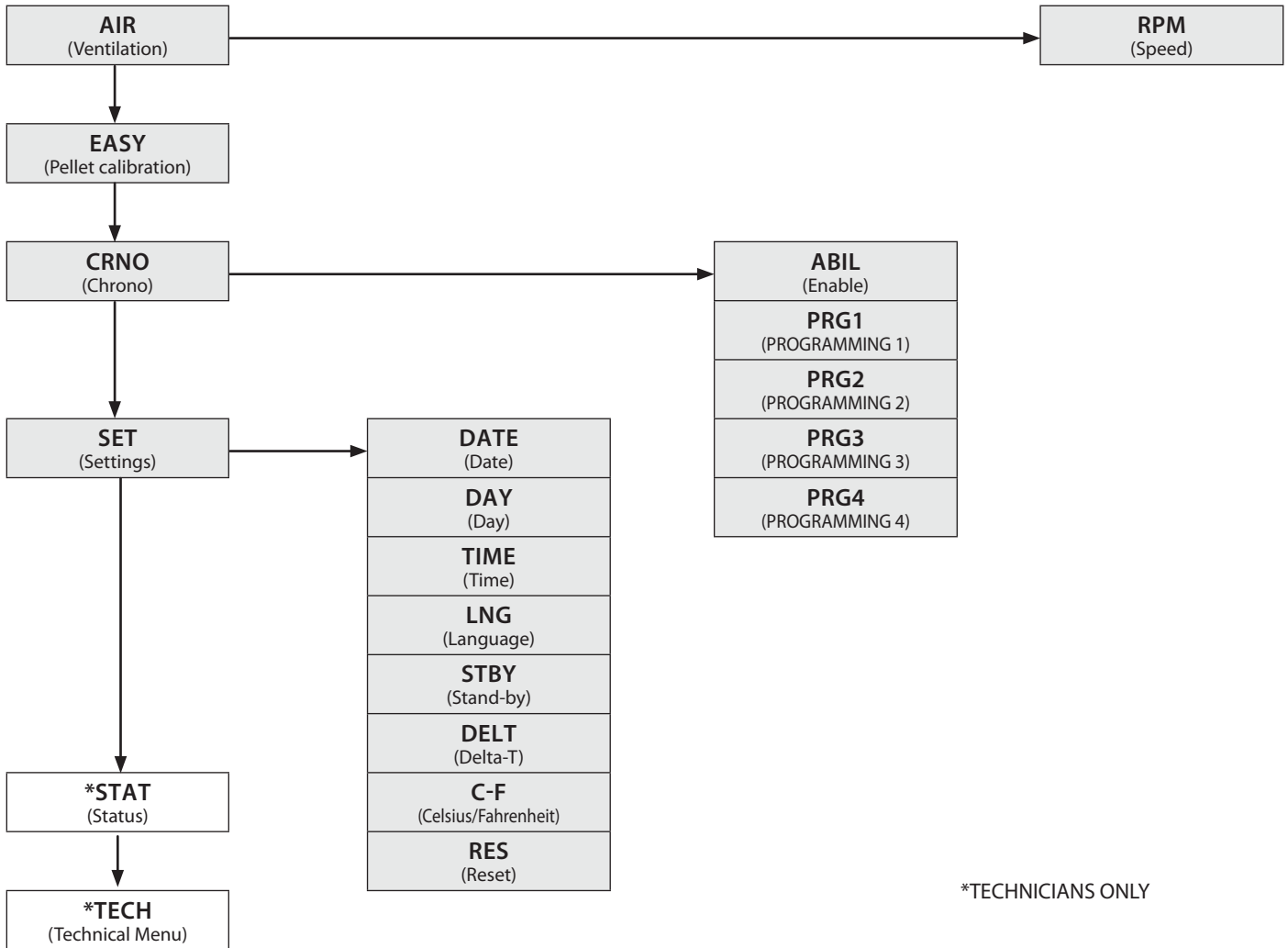

*TECHNICIANS ONLY

BASIC INSTRUCTIONS

The following recommendations must be followed the first times the stove is ignited:

- ♦ It is possible that slight odours are produced due to the drying of the paints and silicone used. Do not remain in the room for long periods.
- ♦ Do not touch the surfaces as they could still be unstable.
- ♦ Ventilate the room well several times.
- ♦ The hardening of surfaces will stop after several heating cycles.
- ♦ This appliance must not be used to burn waste.

Before lighting the stove, the following points must be checked:

- ♦ The hopper must be loaded with pellets
- ♦ The combustion chamber must be clean
- ♦ The burn pot must be completely free and clean
- ♦ Check the hermetic closure of the hopper, fire door and ash drawer
- ♦ Check that the power cable is properly connected
- ♦ The bipolar switch in the rear must be positioned on 1.

REMOTE CONTROL

When using the remote control, you can regulate the heating power, room temperature required and switch the device on/off.

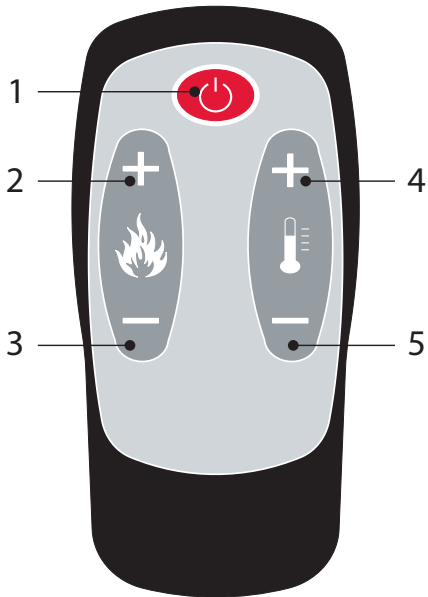

1	ON/OFF	Prolonged pressure turns the stove on or off.
2	POWER INCREASE	Increases operating power
3	POWER DECREASE	Decreases operating power
4	T° INCREASE	Increases the set thermostat
5	T° DECREASE	Decreases the set thermostat.

BATTERY TYPE AND REPLACEMENT

The battery is housed in the lower part of the remote control. To replace it, remove the battery holder (as indicated in the diagram on the back of the remote control), remove or insert the battery following the symbols printed on the remote control and the battery.

One 3V CR2025 lithium coin battery is required to operate the remote control.



IF THE REMOTE CONTROL IS SWITCHED OFF BECAUSE THERE IS NO BATTERY, THE STOVE CAN BE CONTROLLED FROM THE COMMAND PANEL LOCATED ON THE LOWER PART OF THE STOVE. WHEN CHANGING THE BATTERY, MAKE SURE YOU FOLLOW THE SYMBOLS PRINTED ON THE INNER SLOT OF THE REMOTE CONTROL.



NO IGNITION

THE APPLIANCE MAY FAIL TO LIGHT BECAUSE THE AUGER IS EMPTY AND NOT ALWAYS ABLE TO LOAD THE BURN POT WITH THE NECESSARY QUANTITY OF PELLETS IN TIME TO REGULARLY IGNITE THE FLAME. IF THE PROBLEM OCCURS AFTER ONLY A FEW MONTHS OF OPERATION, CHECK THAT THE ROUTINE CLEANING DESCRIBED IN THE STOVE BOOKLET HAS BEEN CARRIED OUT CORRECTLY.

COMMISSIONING SETTINGS

Once the power cable at the back of the generator has been connected, move the switch, also located on the back, to (I).
The switch at the back of the generator powers the generator board.
The generator remains off and an initial screen appears on the panel, displaying OFF.

MAINS POWER FREQUENCY 50/ 60HZ

If the generator is installed in a country with a frequency of 60Hz, the generator will display "POWER FREQUENCY ERROR". In this case, adjust the frequency to 60Hz.

Press and hold key 4 to access the power frequency error menu. Use keys 4 and 5 to select the correct frequency and 2 to confirm and exit.

DATE (DATE)

This menu allows the date to be set.

CONTROLS PROCEDURE

- ◆ Press and hold key 4.
- ◆ Press key 3 until **SET** appears and access with key 4.
- ◆ Press key 3 until **DATE** appears and access with key 4.
- ◆ Use keys 2 and 3 to select the sub-item DAY, MNTH or YEAR to set each one.
- ◆ Access with key 4.
- ◆ Modify with keys 4 and 5 and confirm with key 2
- ◆ Press key 1 several times to exit the menu.

DAY (DATE)

This menu allows the date to be changed. (DAY1 = Monday - DAY7 = Sunday)

CONTROLS PROCEDURE

- ◆ Press and hold key 4.
- ◆ Press key 3 until **SET** appears and access with key 4.
- ◆ Press key 3 until **DAY** appears and access with key 4.
- ◆ Set the day using keys 4 and 5 and confirm with key 2.
- ◆ Press key 1 several times to exit the menu.

TIME (TIME)

This menu allows the time to be set.

CONTROLS PROCEDURE

- ◆ Press and hold key 4.
- ◆ Press key 3 until **SET** appears and access with key 4.
- ◆ Press key 3 until **TIME** appears and access with key 4.
- ◆ Use keys 2 and 3 to select and set HOUR or MIN.
- ◆ Key 4 to access, 4 and 5 to modify and 2 to save
- ◆ Press key 1 several times to exit the menu.

LNG (LANGUAGE)

This menu allows the preferred language to be selected. The languages available are: Italian - English - German - French - Spanish - Portuguese

CONTROLS PROCEDURE

- ◆ Press and hold key 4.
- ◆ Press key 3 until **SET** appears and access with key 4.
- ◆ Press key 3 until **LNG** appears and access with key 4.
- ◆ Set the language using keys 4 and 5 and confirm with key 2.
- ◆ Press key 1 several times to exit the menu.

C-F (CELSIUS/FAHRENHEIT)

This menu allows to you set the desired unit of measurement. "C" for Celsius (°C) - "F" for Fahrenheit (°F)

CONTROLS PROCEDURE

- ◆ Press and hold key 4.
- ◆ Press key 3 until **SET** appears and access with key 4.
- ◆ Press key 3 until **C-F** appears and access with key 4.
- ◆ Set the unit of measurement using keys 4 and 5 and confirm with key 2.
- ◆ Press key 1 several times to exit the menu.

OPERATION AND LOGIC

IGNITION

Once the points listed previously have been checked, press key 1 for three seconds to ignite the stove. There are 15 minutes available to detect the presence of the flame during the ignition phase. When the control temperature is reached, stove interrupts the ignition phase and switches to PREPARATION.

PREPARATION

During the preparation phase, the stove stabilises combustion, increasing it progressively, to then start ventilation and switch to WORK

WORK

In the work phase, the stove switches to the Set Power defined by the user, heating the room until Set Thermostat is achieved. See next heading.

SET THERMOSTAT

The Set room thermostat can be set with keys 4 and 5, from LOU - 7°C - 40°C - HOT. If the value is between 07°C-40°C, the stove controls the room temperature by means of an on-board probe. Once the set temperature has been reached, the stove automatically decreases the power, ensuring the best comfort and reducing pellet consumption. This process is called "modulation".

LOU - HOT

If the Set Thermostat is "LOU" (set under the 7° threshold), temperature control passes to the additional thermostat contact, thus bypassing the on-board temperature probe.

If the contact is closed (fulfilled), the stove decreases to minimum value.

If the contact is open (request), the stove works at the set power.

If the setting is on "HOT" (set above 40°C), the stove only works at the set power, thus bypassing the external contact and the temperature probe.

SET POWER

Set Power has 5 operating levels. The power can be changed with keys 2 or 3.

Power 1 = minimum level - Power 5 = maximum level.

Press key 1 to exit and save the change.

AUTO BLOW

During the work phase, the stove cleans the burn pot at regular intervals with an "AUTO BLOW".

When this procedure starts, a message is displayed. During the "AUTO BLOW" procedure, the pellet feed slow down and the fumes motor increases.

After cleaning, the stove resumes working at normal operational conditions.

SWITCH-OFF

Press key 1 for three seconds.

Once this operation has been performed, the appliance automatically enters the switch-off phase, blocking the supply of pellets.

The flue gas exhaust motor and the hot air flow motor will remain on until the stove temperature has dropped below the safety settings.

RE-IGNITION

The stove can only be re-ignited if the temperature of the exhaust fumes is lower than the pre-set threshold and the minimum safety time has passed.



DO NOT USE ANY TYPE OF FLAMMABLE LIQUIDS FOR IGNITION!

DO NOT ALLOW THE BAG OF PELLETS TO COME INTO CONTACT WITH THE BOILING HOT STOVE DURING THE FILLING PHASE!

IN THE EVENT OF CONTINUED FAILURE TO LIGHT, CONTACT AN AUTHORISED TECHNICIAN.



IT IS FORBIDDEN TO USE THE DEVICE WITHOUT A PARTITION (A) AND FLAME GUARD (B).
 REMOVAL WILL COMPROMISE THE SAFETY OF THE PRODUCT AND RESULT IN THE IMMEDIATE NULLIFICATION OF THE WARRANTY PERIOD.
 IN THE EVENT OF WEAR OR DETERIORATION, REQUEST THE PART'S REPLACEMENT FROM THE AFTER-SALES SERVICE.
 (REPLACEMENT DOES NOT FALL WITHIN THE PRODUCT WARRANTY AS THE PART IS SUBJECT TO WEAR).

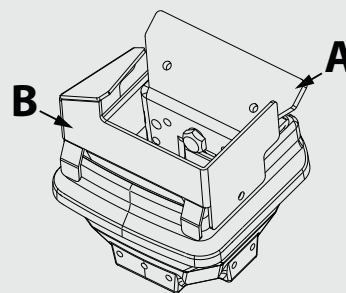

AIR (VENTILATION)

The menu allows you to adjust the speed (-2, -1, 0, +1, +2) of the front fan.

CONTROLS PROCEDURE

- ◆ Press and hold key 4.
- ◆ Access **AIR** with key 4.
- ◆ Access **RPM** with key 4.
- ◆ Adjust speed with keys 4-5 and 2 to confirm.
- ◆ Press key 1 several times to exit the menu.

EASY (PELLET CALIBRATION)

The volumetric weight of the pellet is the ratio between the weight and the volume of the pellet. This ratio may change while keeping the quality of the pellet unchanged. By using the **EASY** function, it is possible to change the calibration of the volumetric weight by increasing or decreasing the pre-set values.

In the stove program, the available values go from “- 3” to “+ 3”; all stoves are calibrated during production with the optimal value which is 0

If you notice an excessive deposit on the burning pot, access the **EASY** program and lower the value of one unit to “- 1”; then wait until the next day and if there is no improvement, decrease again, to a maximum of “- 3”. Instead, if it is necessary to increase the calibration of the volumetric weight of the pellet, go from the factory value “0” to “+ 1, + 2, + 3” as required.

CONTROLS PROCEDURE

- ◆ Press and hold key 4.
- ◆ Press key 3 until **EASY** appears and access with key 4.
- ◆ Adjust using keys 4 and 5 and confirm with key 2.
- ◆ Press key 1 several times to exit the menu.

EXCESSIVE PELLET DEPOSIT IN THE BURNING POT			NORMAL OPERATION	MINIMUM PELLET DEPOSIT IN THE BURNING POT		
-3	-2	-1	0	+1	+2	+3
THIRD DECREASE RANGE IF THE FIRST TWO ARE NOT ENOUGH	SECOND DECREASE RANGE IF THE FIRST IS NOT ENOUGH	FIRST DECREASE RANGE (TEST FOR 1 DAY)	OPTIMAL FACTORY VALUE	FIRST INCREASE RANGE	SECOND INCREASE RANGE IF THE FIRST IS NOT ENOUGH	THIRD INCREASE RANGE IF THE FIRST TWO ARE NOT ENOUGH

N.B.: If this calibration does not solve the pellet deposit in the burn pot, please contact your local after-sales centre.

STAT (STATUS)

References reserved for the technician

CRNO (CHRONO)

This function allows the stove's ignition and switch-off to be automatically programmed.

The factory setting for CHRONO is off.

The chrono allows the programming of 4 time slots within a day, which can be used every day of the week.

Ignition and switch-off times can be set for each time slot, along with the specific days of application for the programmed time slot, the desired temperature and power setting.

Current day and time settings are essential for the correct operation of the Chrono.

Recommendations

Before using the chrono function, you must set the current day and time, so check that you have followed the points listed in the sub-chapter "DATE, DAY and TIME". To use the chrono function correctly, you must activate it as well as program it. The four time slots can be overlapped using the time switch on and off settings, This allows you to obtain a combination of times in which you can set different temperatures and power without influencing the stove work status.

NB: if overlapping time slots are set, the stove will stay on until the latest switch-off time.

ABIL (ENABLE)

Allows the chrono and the different stove time slots to be enabled/disabled.

CONTROLS PROCEDURE

- ◆ Press and hold key 4.
- ◆ Press key 3 until **CRNO** appears and access with key 4.
- ◆ Press 4 to access **ENABLE**, 4-5 to select **ON** and **OFF**, and 2 to confirm.
- ◆ Press key 1 several times to exit the menu.

PRG 1-4 (PROGRAMMING 1-4)

PrG x allows you to set the ignition time (**STRT**) and switch-off time (**STOP**), the days (**DAY1**= Monday / **DAY7** = Sunday) included in the programmed slot and the temperature (**TEMP**) (lou - 7° - 40° - hot), as well as the power (**POW.**) required. Current day and time settings are essential for the correct operation of the Chrono.

CONTROLS PROCEDURE

- ◆ Press and hold key 4.
- ◆ Press key 3 until **CRNO** appears and access with key 4.
- ◆ Select the slot using keys 2-3 and access it with 4.
- ◆ Select one of the following options: **STRT**, **STOP**, **DAY**, **TEMP** and **POW.** and access with 4
- ◆ Adjust using keys 4 and 5 and confirm with key 2.
- ◆ Press key 1 several times to exit the menu.

CRNO	>	ABIL	<i>Enables/disables all the set chrono</i>	
		∨		
PRG1	>	ABIL	<i>On/Off</i>	<i>Enabling/disabling PRG 1</i>
		∨	STRT	<i>OFF-00:00-23:50</i> <i>PRG1 start time</i>
		∨	STOP	<i>OFF-00:00-23:50</i> <i>PRG1 stop time</i>
		∨	DAY1...DAY7	<i>On/off</i> <i>Enabling/disabling days for PRG1</i>
		∨	TEMP	<i>LOU - 07- 40 °C - HOT</i> <i>Set thermostat PRG1</i>
		∨	POW.	<i>1-5</i> <i>Set power PRG1</i>
		∨		
PRG2	>	ABIL	<i>On/Off</i>	<i>Enabling/disabling PRG 2</i>
		∨	STRT	<i>OFF-00:00-23:50</i> <i>PRG2 start time</i>
		∨	STOP	<i>OFF-00:00-23:50</i> <i>PRG2 stop time</i>
		∨	DAY1...DAY7	<i>On/off</i> <i>Enabling/disabling days for PRG2</i>
		∨	TEMP	<i>LOU - 07- 40 °C - HOT</i> <i>Set thermostat PRG2</i>
		∨	POW.	<i>1-5</i> <i>Set power PRG2</i>
		∨		
PRG3	>	ABIL	<i>On/Off</i>	<i>Enables/disables PRG3</i>
		∨	STRT	<i>OFF-00:00-23:50</i> <i>PRG3 start time</i>
		∨	STOP	<i>OFF-00:00-23:50</i> <i>PRG3 stop time</i>
		∨	DAY1...DAY7	<i>On/off</i> <i>Enabling/disabling days for PRG3</i>
		∨	TEMP	<i>LOU - 07- 40 °C - HOT</i> <i>Set thermostat PRG3</i>
		∨	POW.	<i>1-5</i> <i>Set power PRG3</i>
		∨		
PRG4	>	ABIL	<i>On/Off</i>	<i>Enabling/disabling PRG 4</i>
			STRT	<i>OFF-00:00-23:50</i> <i>PRG4 start time</i>
			STOP	<i>OFF-00:00-23:50</i> <i>PRG4 stop time</i>
			DAY1...DAY7	<i>On/off</i> <i>Enabling/disabling days for PRG4</i>
			TEMP	<i>LOU - 07- 40 °C - HOT</i> <i>Set thermostat PRG4</i>
			POW.	<i>1-5</i> <i>Set power PRG4</i>



WHEN THE WEEKLY PROGRAMMER IS SHOWN ON THE DISPLAY, THE INDICATOR LIGHT WILL BE ON.



EXAMPLE OF CHRONO OVERLAPPING TIME/SLOTS

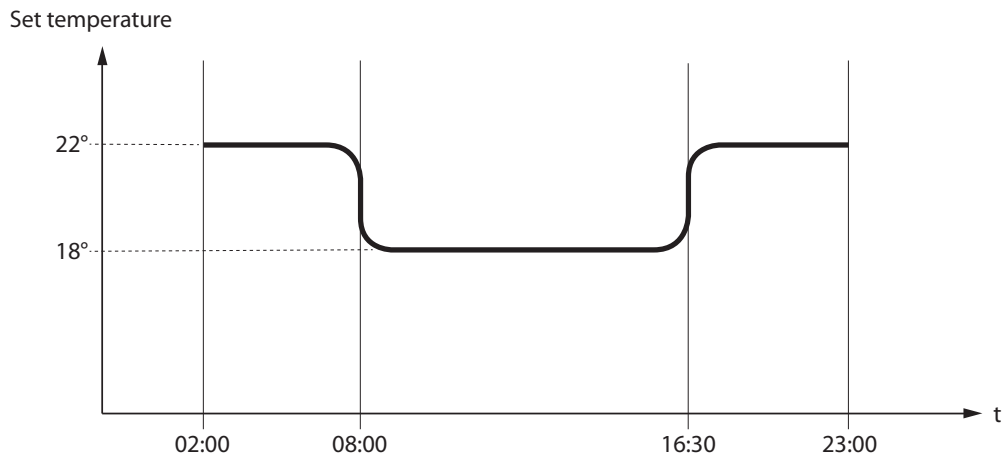
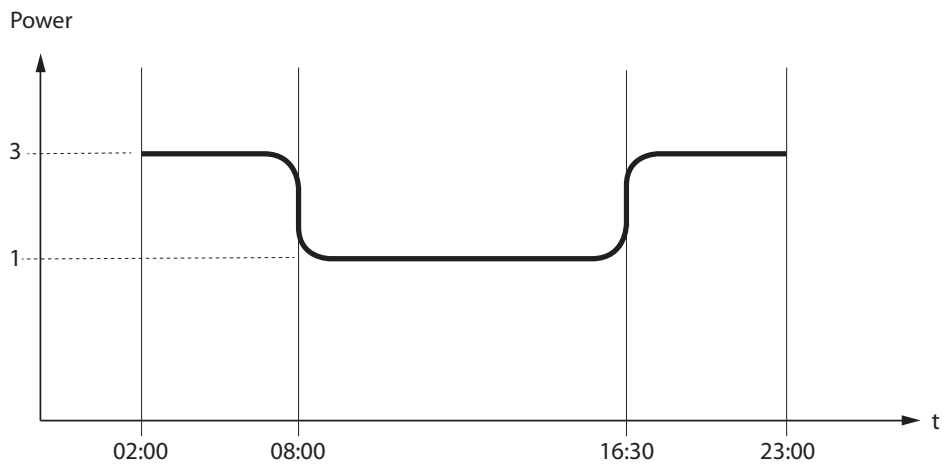
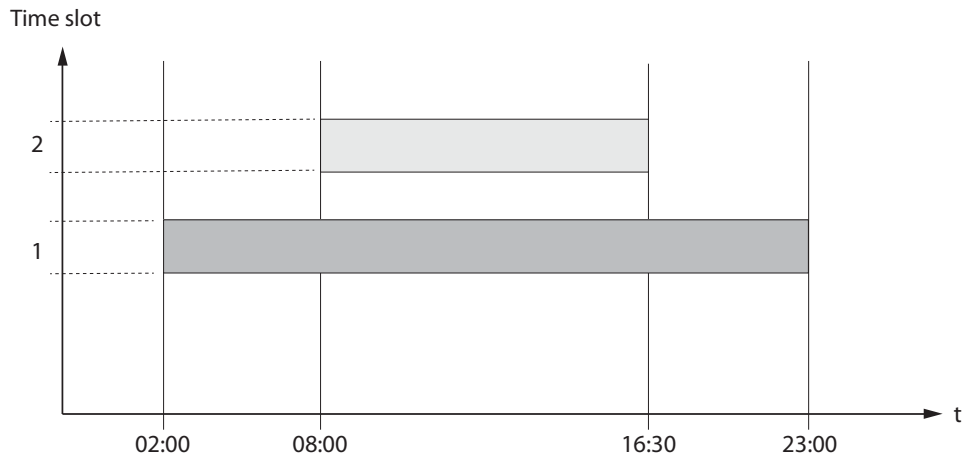

	Time slot 1	start 02:00 stop 23:00	power 3 - set temp 22°C
	Time slot 2	start 08:00 stop 16:30	power 1 - set temp 18°C
	stove operation		

SET (SETTINGS)

- ◆ DATE
- ◆ DAY
- ◆ TIME
- ◆ LNG
- ◆ C-F

SEE CHAPTER: COMMISSIONING SETTINGS.

STBY (STAND-BY)

The stand-by function is used if the stove needs to be turned off immediately instead of a power modulation.

CONTROLS PROCEDURE

- ◆ Press and hold key 4.
- ◆ Press key 3 until **SET** appears and access with key 4.
- ◆ Press key 3 until **STBY** appears and access with key 4.
- ◆ Enable/disable using keys 4 and 5 and confirm with key 2.
- ◆ Press key 1 several times to exit the menu.

STBY FUNCTION SET TO ON

When the Stand-by function is active (ON), if the room temperature exceeds the **SET THERMOSTAT** value + **DELTA**, the stove will switch off after a pre-set (default) delay period, displaying **STBY**.

When the room temperature is lower than the **SET THERMOSTAT** - **DELTA**, the stove cools down, if necessary, and then switches off.

STBY FUNCTION SET TO OFF (FACTORY DEFAULT SETTING)

In the event the Stand-by function is not activated (OFF), if the stove exceeds the set room temperature, it will switch to the minimum power level, modulating and displaying **MODULATION**. When the room temperature is lower than the **SET THERMOSTAT** the stove will restart at the set power and **WORK** will be displayed on the screen.

OPERATION WITH SUPPLEMENTARY THERMOSTAT (OPTIONAL)

STBY FUNCTION SET TO OFF (FACTORY DEFAULT SETTING)

In the event the Stand-by function is not activated (OFF), if the stove reaches the room temperature set on the supplementary thermostat (closed contact), it will switch to the minimum power level and display **MODULATION**. When the room temperature is lower than the set value on the supplementary thermostat (open contact), the stove will restart at the set power, and **WORK** will be displayed on the screen.

STBY FUNCTION SET TO ON

If the STAND-BY function is activated (ON), when the room temperature set on the supplementary thermostat is reached (closed contact), the stove will switch off after a pre-set (default) delay period, and **STBY** will be displayed on the screen.

When the room temperature is lower than the supplementary thermostat (open contact), the stove cools down, if necessary, and then re-ignites.



**FOR CORRECT OPERATION, SET THERMOSTAT SHOULD BE SET IN LOU.
> SEE THE INSTALLATION CHAPTER SUPPLEMENTARY THERMOSTAT**

DELTA (DELTA-T)

This function allows you to set the delta-t for igniting and switching off the stove, used as a room temperature adjustment interval if there is no external thermostat. The exact temperature for ignition is **SET THERMOSTAT** - Delta-T. The temperature for switching off is **SET THERMOSTAT** + Delta-T.

The possible values for Delta-T range from: 0.5 - 5°C

CONTROLS PROCEDURE

- ◆ Press and hold key 4.
- ◆ Press key 3 until **SET** appears and access with key 4.
- ◆ Press key 3 until **DELTA** appears and access with key 4.
- ◆ Adjust with keys 4-5 and 2 to confirm.
- ◆ Press key one several times to confirm and exit the menu.

RES (RESET)

Allows the user to reset all modifiable values to the default values.

CONTROLS PROCEDURE

- ◆ Press and hold key 4.
- ◆ Press key 3 until **SET** appears and access with key 4.
- ◆ Press key 3 until **RES** appears and access with key 4.
- ◆ Use keys 4 and 5 to select ON or OFF and confirm with 2.

ADDITIONAL FUNCTIONS

FIRST LOAD

This function allows you to activate the gearmotor for loading pellets continuously. Before starting the function, make sure the stove is cold and "OFF".

Press keys 2 + 5 at the same time for two seconds until the message "FIRST LOAD". To stop continuous loading, just press and hold key 1 for 3 seconds.

DELAY SWITCH-OFF

You can program a delayed switch-off for the stove. For example, if it is 8 pm and the delayed switch-off is set to 1h, the stove will automatically switch off at 9 pm.

If you press and hold keys 2+4 at the same time, the screen "DELAY SWITCH-OFF" will appear, alternating with the countdown (this setting can only be configured if the stove is in the preparation phase or working).

Use keys 4 and 5 to increase/decrease the number of hours after which the stove will automatically start the final cleaning phase.

The number of hours range from OFF, 1 to 9.

Press key 1 to confirm and return to the home page.

The remaining operating time is indicated by displaying at one-minute intervals "SWITCH OFF IN HOURS" and the time "xx:xx".

SUPPLEMENTARY THERMOSTAT INSTALLATION (OPTIONAL)

The stove can control the room temperature through a supplementary thermostat (optional).

After the stove is turned on (by pressing key 1 or through the chrono mode), it will work to reach the temperature set on the thermostat, displaying WORK (open contact). The standard room sensor is by-passed automatically.

When the thermostat temperature has been reached (closed contact), the stove switches to minimum power level and displays MODULATION ON THE SCREEN.

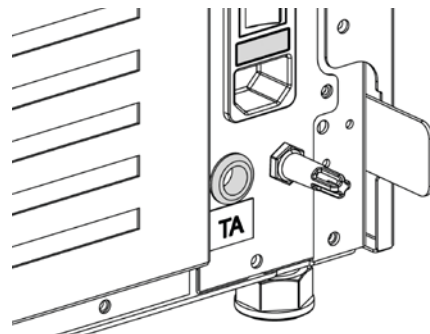

IF A SUPPLEMENTARY THERMOSTAT HAS BEEN INSTALLED, THE CONNECTION MUST BE MADE BY THE QUALIFIED TECHNICIAN DIRECTLY IN THE BOARD. CONTACT THE DEALER FOR FURTHER DETAILS.

CLEANING AND MAINTENANCE

ALWAYS FOLLOW THE INSTRUCTIONS IN COMPLETE SAFETY!

- ♦ Make sure that the power supply cable plug is disconnected, since the generator could be programmed to switch-on.
- ♦ That the generator is completely cold.
- ♦ The ashes are cold.
- ♦ Ensure proper ventilation of the room when cleaning the stove.
- ♦ Lack of cleaning jeopardises correct operation and safety!

MAINTENANCE

For correct operation, the generator must undergo routine maintenance by a qualified technician, at least once a year. The periodic inspection and maintenance operations must always be performed by specialised, qualified technicians, who operate in accordance with the laws in force and the instructions given in this use and maintenance manual.



EVERY YEAR, GET THE FUME DISCHARGE SYSTEM, THE FLUE PIPES AND THE "T" FITTINGS AND INSPECTION CAPS CLEANED - IF PRESENT, ALSO THE ELBOWS AND HORIZONTAL SECTIONS!

THE CLEANING FREQUENCY OF THE GENERATOR IS INDICATIVE! IT DEPENDS ON THE QUALITY OF THE PELLETS USED AND FREQUENCY OF USE.

THESE OPERATIONS MUST BE PERFORMED MORE FREQUENTLY.

PERIODIC CLEANING BY THE USER

As indicated in this use and maintenance manual, periodic cleaning must be performed paying great attention, after having read the indications, to the procedures and times described herein.

CLEANING THE SURFACES AND COVERING

Never use abrasive or chemically aggressive detergents for cleaning!

The surfaces must be cleaned when the generator and covering are completely cold. For maintenance of surfaces and metal parts, just use a cloth dampened in water or water and neutral soap.

Failure to comply with the indications can damage the surfaces of the generator and cause the warranty to become null and void.

CLEANING THE CERAMIC GLASS

Never use abrasive or chemically aggressive detergents for cleaning!

The ceramic glass must only be cleaned when the glass is completely cold.

To clean the ceramic glass, simply use a dry brush and some damp newspaper dipped in ash. If the glass is very dirty, use a specific cleaning agent for ceramic glass. Spray a small amount on a cloth and use it on the ceramic glass. Do not spray the cleaning agent or any other liquid directly on the glass or seals!

Failure to comply with these instructions may damage the surfaces of the ceramic glass and cause the invalidation of the warranty.

CLEANING THE PELLET TANK

When the tank is completely empty, disconnect the power cable of the generator and remove the residues first (dust, chippings, etc.) from the empty tank, and then fill it.

TO FIND OUT WHERE YOUR NEAREST SERVICE CENTRE IS, CONTACT YOUR DEALER OR GO TO THE WEBSITE:
WWW.LANORDICA-EXTRAFLAME.COM

EVERY DAY

BURN POT AND COMBUSTION CHAMBER:

- ◆ Vacuum the residue in the burn pot
- ◆ Remove the burn pot completely from the relevant compartment;
- ◆ Vacuum the ash from the burn pot slot, ignition plug pipe holder and combustion chamber.
- ◆ Unblock all the holes in the burn pot using the poker supplied.
- ◆ Re-position the burn pot in its slot and push it towards the fire wall.

NOTE: Use a suitable ash vacuum cleaner with a special separate container for the ashes collected

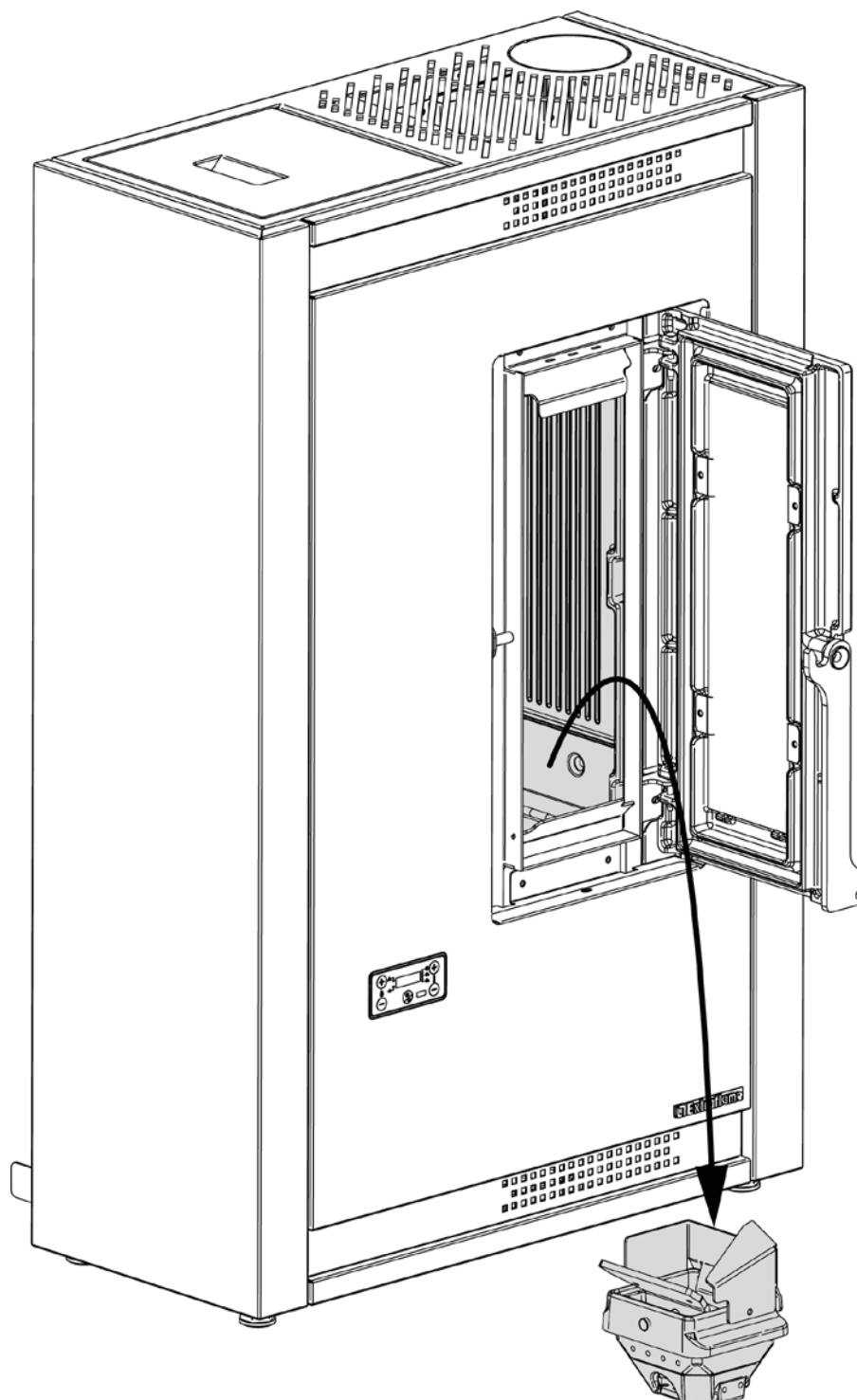

EVERY 30 DAYS

CLEANING THE TUBE HEAT EXCHANGER

- ◆ Vacuum the residue in the burn pot
- ◆ Remove the burn pot completely from the relevant compartment (A);
- ◆ Vacuum the ash from the burn pot slot, ignition plug pipe holder and combustion chamber.
- ◆ Unblock all the holes in the burn pot using the poker supplied.
- ◆ Release the central wall of the fireplace from the clamps, by sliding it upwards (B).

- ◆ Remove the cast-iron wall by tilting it (C).
- ◆ Once the central cast iron wall has been removed, clean the tube heat exchanger (D).

After cleaning, replace the cast iron fire wall and reposition the burn pot in its slot pushing it towards the fire wall.

NOTE: Use a suitable ash vacuum cleaner with a specific container for separation of the ash collected.

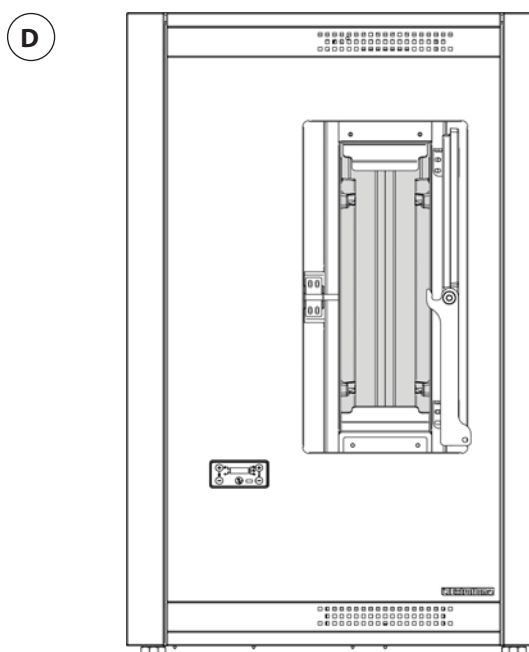
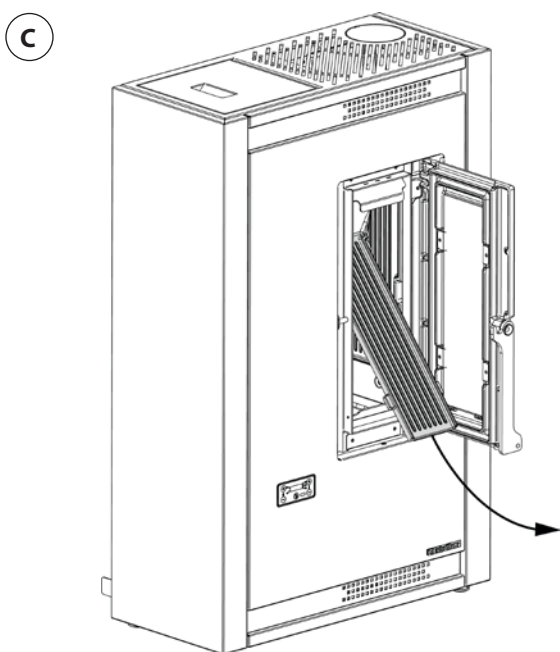
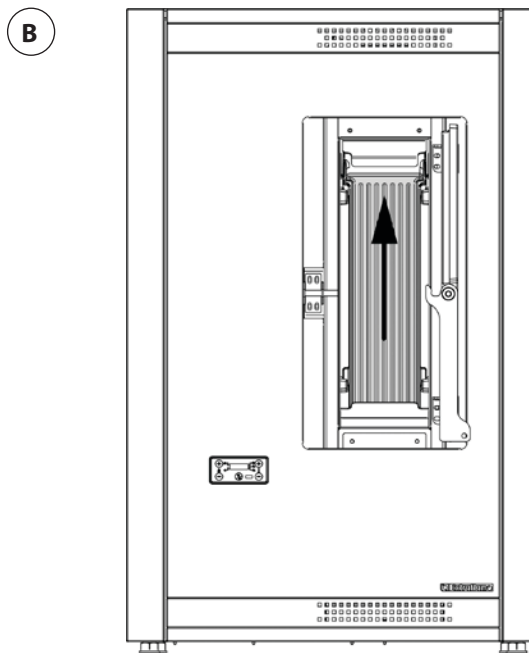
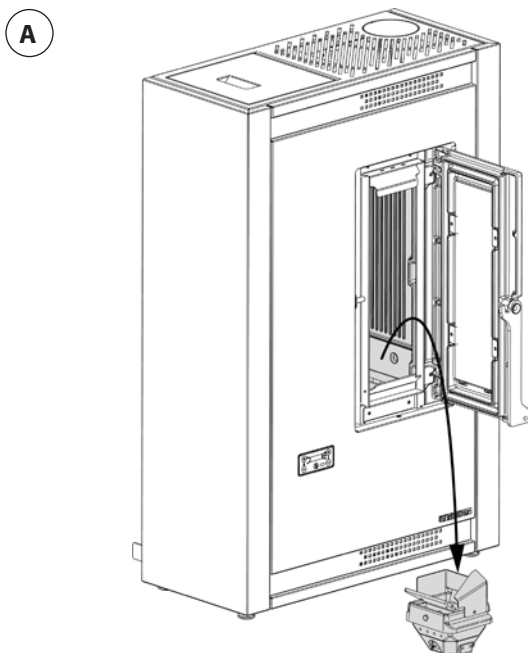

EVERY 30 DAYS

Cleaning "T" fitting with inspection cap outside the stove: check and clean at least once a month



THE GASKETS FOR THE PELLET HOPPER, BURN POT AND FIRE DOOR ENSURE THAT THE STOVE WORKS PROPERLY. IT IS NECESSARY TO PERIODICALLY CHECK THEM; IF THEY SEEM TO BE WORN OR DAMAGED, THEY MUST BE REPLACED IMMEDIATELY.

THESE OPERATIONS MUST BE CARRIED OUT BY A QUALIFIED TECHNICIAN.



A CLEAN BURN POT GUARANTEES CORRECT OPERATION!

BY MAKING SURE THE BURN POT AND ITS HOLES ARE ALWAYS CLEAN FROM ANY COMBUSTION RESIDUE, EXCELLENT COMBUSTION BY THE GENERATOR IS GUARANTEED OVER TIME, PREVENTING ANY MALFUNCTIONING THAT COULD REQUIRE TECHNICIAN INTERVENTIONS.

THE "EASY SETUP" FUNCTION IN THE USER MENU CAN BE USED TO ADAPT COMBUSTION ON THE BASIS OF THE NEEDS DESCRIBED.

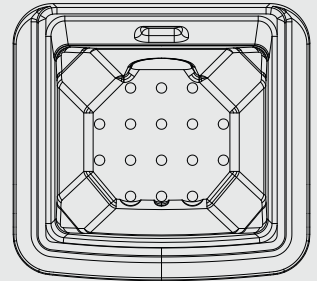

BURN POT DETAIL

The burn pot consists of several parts:

The burn pot + partition (A) where combustion takes place physically and a flame guard (B).

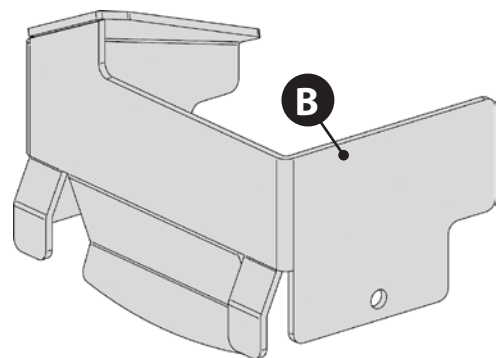
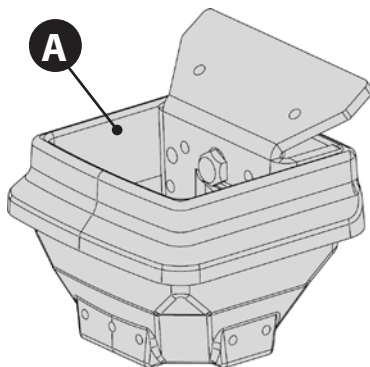

When cleaning and removing the burn pot, remove the flame guard (B) by lifting it. Perform the same operation in reverse order to re-assemble.

After having re-positioned, always make sure:

- that the flame guard is resting correctly on the burn pot.
- that the burn pot has been pushed towards the fire wall (D) (to the left).

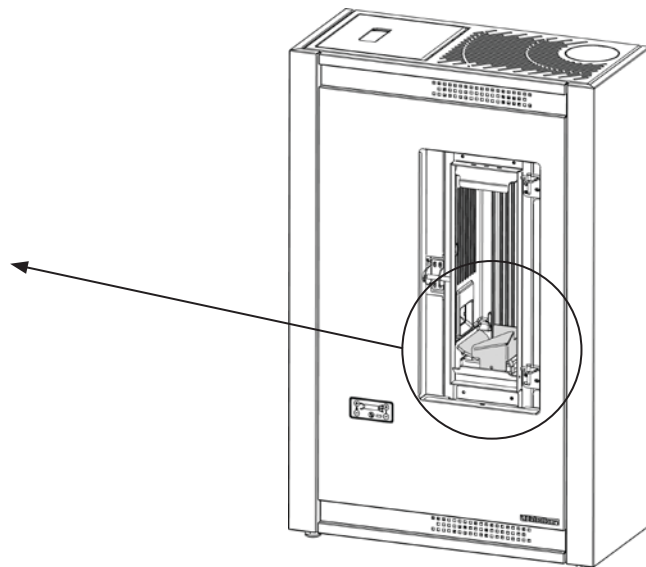
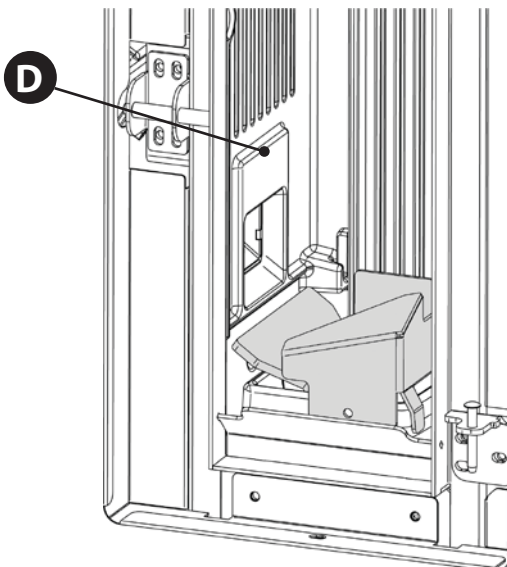



IF THE POWER SUPPLY CABLE IS DAMAGED, IT MUST BE REPLACED BY THE AFTER-SALES SERVICE OR BY A SIMILARLY QUALIFIED PERSON, SO AS TO AVOID ALL RISKS.

ROUTINE MAINTENANCE PERFORMED BY QUALIFIED TECHNICIANS

Routine maintenance must be performed at least once a year.

Using pellets as solid fuel, the generator requires annual routine maintenance, which must be performed by a **qualified technician, using only original spare parts.**

Failure to comply can jeopardise safety of the appliance and make the warranty null and void.

Respecting the frequencies of cleaning reserved for the user described in the use and maintenance manual, the generator is guaranteed correct combustion over time, preventing any anomalies and/or malfunctioning that could require more interventions of the technician. Requests for routine maintenance are not contemplated in the product warranty.

GASKETS: PELLET HOPPER LID, DOOR, ASH DRAWER AND BURN POT

The gaskets guarantee the tightness of the stove and its consequent good functioning.

They must be controlled periodically. They must be replaced immediately if they are worn or damaged.

These operations must be carried out by a qualified technician.

CONNECTION TO THE FLUE

Vacuum and clean the pipe that leads to the flue yearly or any time that it is necessary. If there are horizontal tracts, the residue must be removed before it can prevent the passage of the fumes.

DECOMMISSIONING (END OF SEASON)

At the end of each season, before turning the stove off, it is advisable to empty the pellet hopper out completely, vacuum any residue of pellets and dust.

Furthermore, please disconnect the generator from the mains electricity and, for greater safety especially in the presence of children, remove the power supply cable.

Routine maintenance must be performed at least once a year.

TO FIND OUT WHERE YOUR NEAREST SERVICE CENTRE IS, CONTACT YOUR DEALER OR GO TO THE WEBSITE:

WWW.LANORDICA-EXTRAFLAME.COM

ROUTINE MAINTENANCE

THE IMAGES ARE FOR ILLUSTRATIVE PURPOSES ONLY.

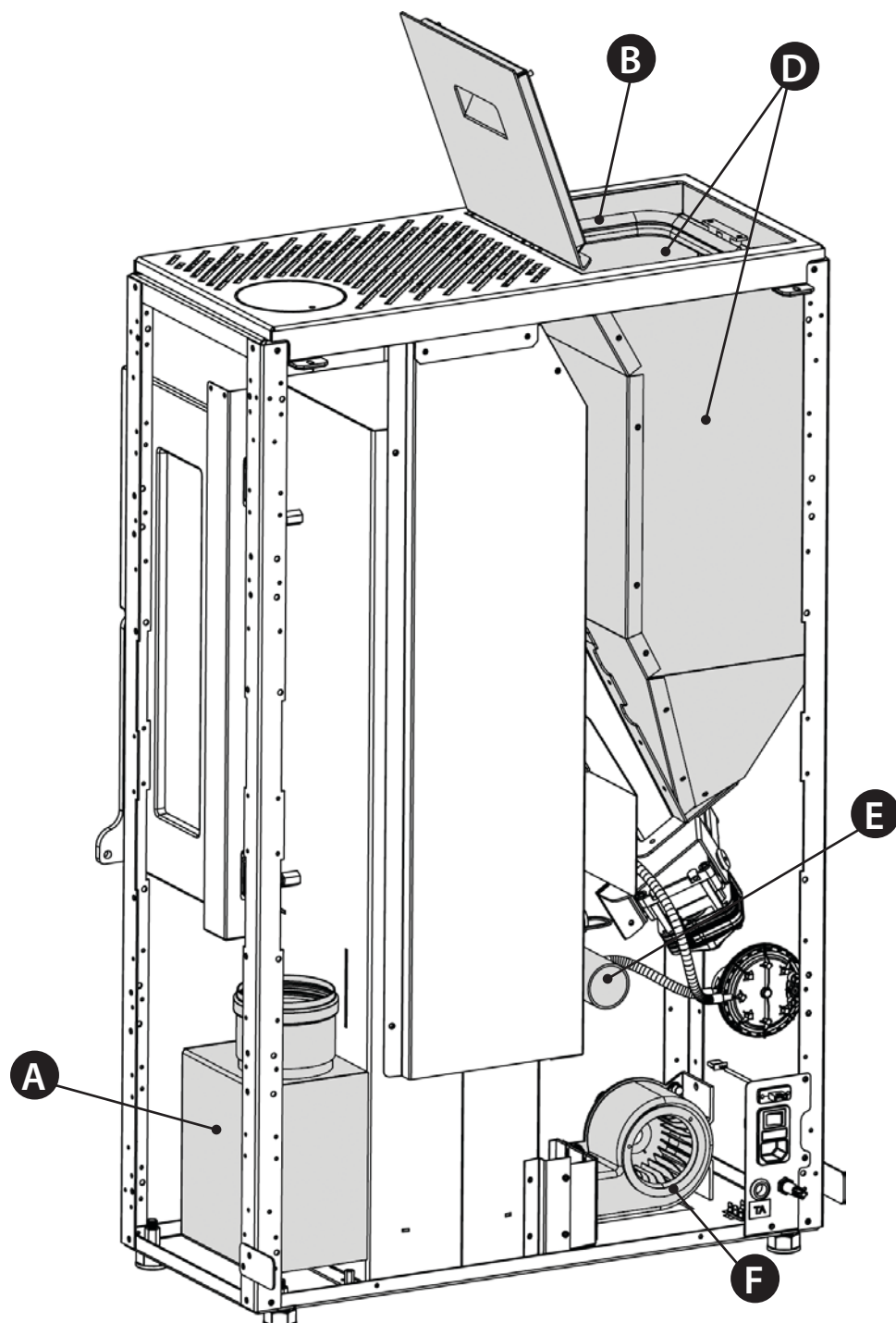

THE IMAGES ARE FOR ILLUSTRATIVE PURPOSES ONLY.

A	Fumes motor (disassembly and cleaning and fumes and "T" pipes), new silicone or gasket in the points indicated.
B	Gaskets, pellet hopper and door (replace them and apply silicone where required)
C	Combustion chamber and heat exchanger (full cleaning) including ignition-plug pipe
D	Hopper (complete emptying and cleaning) and check gasket.
E	Check the air intake pipe and check/clean the mechanical pressure switch
F	Room air fan disassembly and removal of dust and pellet debris.

ROUTINE MAINTENANCE

THE IMAGES ARE FOR ILLUSTRATIVE PURPOSES ONLY.

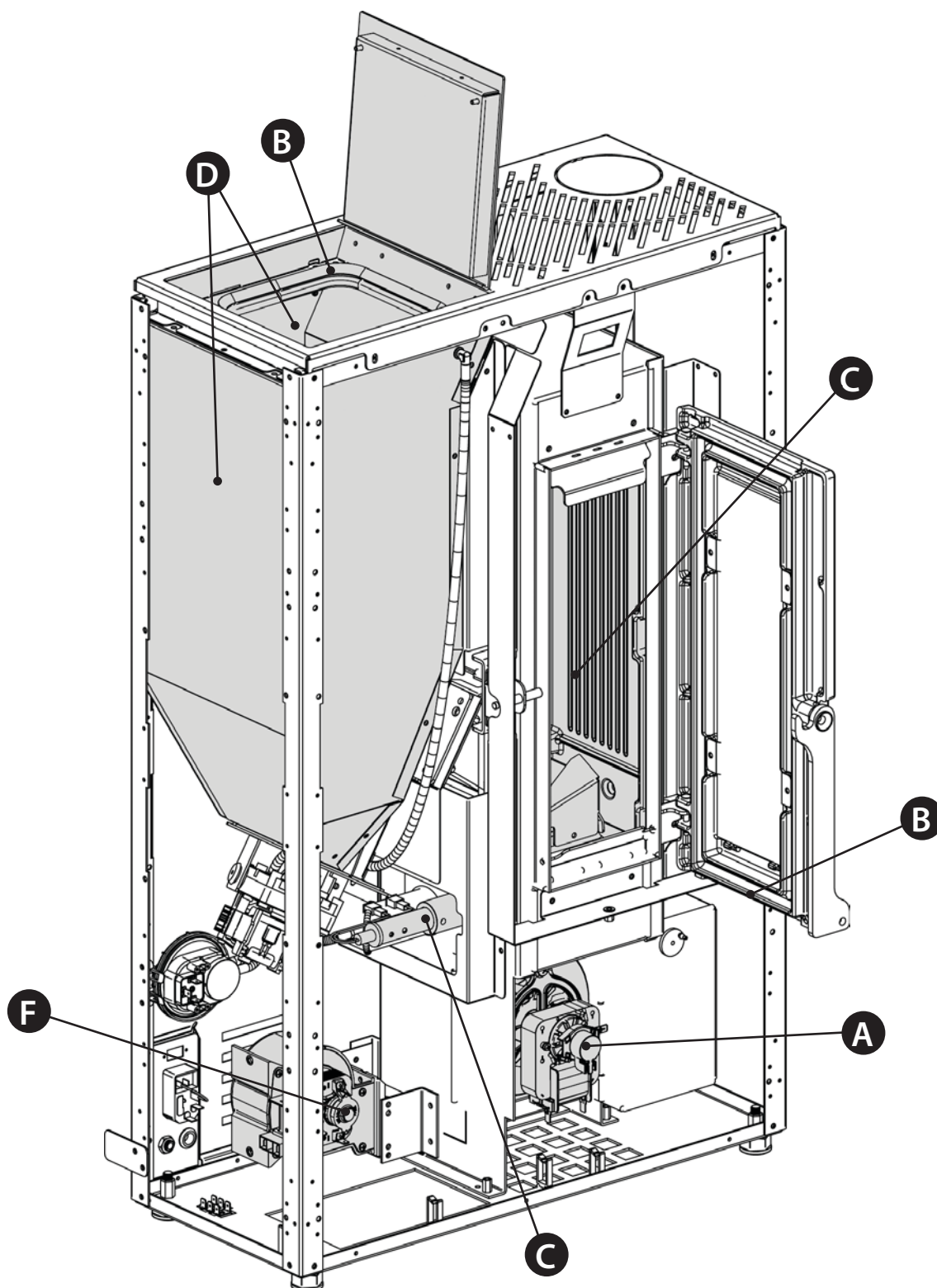

A	Fumes motor (disassembly and cleaning and fumes and "T" pipes), new silicone or gasket in the points indicated.
B	Gaskets, pellet hopper and door (replace them and apply silicone where required)
C	Combustion chamber and heat exchanger (full cleaning) including ignition-plug pipe
D	Hopper (complete emptying and cleaning) and check gasket.
E	Check the air intake pipe and check/clean the mechanical pressure switch
F	Room air fan disassembly and removal of dust and pellet debris.

DISPLAYS

DISPLAY	REASON
OFF	Generator off
START	The start-up phase is in progress
PELLET LOADING	Continuous pellet feeding is in progress during the ignition phase
IGNITION	The ignition phase is in progress
PREPARATION	The preparation phase is in progress
WORK	The normal work phase is in progress
MODULATION	The generator is working at minimum
FINAL CLEANING	The final cleaning is in progress
STAND-BY	Generator off waiting for re-ignition due to the external thermostat.
COOLING STAND BY	A new ignition is attempted when the generator has just been switched off. When the generator switches off, you must wait for the complete shutdown of the fumes motor, then clean the burn pot. The generator can only be re-ignited when these operations have been performed.
BLACK OUT STAND BY	The generator is cooling after a power cut. Once cooling is completed, it will re-start automatically
AUTO BLOW	The automatic blow is active
SERVICE	When this message appears, contact the technician authorised to perform routine maintenance on the stove. If the cleaning is not performed, the message will appear at every start-up but without interrupting the normal operation of the stove.

ALARMS

DISPLAY	EXPLANATION	SOLUTION
	Indicates the presence of an alarm.	On: indicates the presence of an alarm. The alarm can only be reset if the fumes motor has stopped and 15 minutes have passed since the alarm was displayed, by pressing key 1 for 3 seconds.
E00	Fumes motor fault	Contact after-sales centre
E01	Fumes probe fault.	Contact after-sales centre
E02	High fumes temperature	Check pellet feed (see "Easy"), if the problem cannot be solved, contact an authorised technician.
E03	NO IGNITION The pellet hopper is empty. Pellet feed calibration inadequate. Thermostat bulbs tripped.	Check for the presence of pellets in the hopper. Adjust the pellet flow (see "Easy"). Check the procedures described in the "Ignition" chapter. Check the thermostats with bulbs (see chapter on Resetting)
E04	NO FLAME The pellet hopper is empty. No pellet feed. The gearmotor does not feed pellets.	Check for the presence of pellets in the hopper. Adjust the pellet flow (see "Easy").
E05	DEPR ALARM The door is not closed correctly. The ash drawer is not closed correctly. The combustion chamber is dirty. The fumes exhaust pipe is blocked/dirty.	Check hermetic door closure. Check hermetic closure of the ash drawer. Check cleanliness of the fumes pipe and the combustion chamber.
E06	NO IGNITION BLACK OUT No current during the ignition phase.	Turn the stove off using key 1 and repeat the procedure described in the "Ignition" chapter. Other reset operations should be performed by an authorised technician.
E07	Triac Abnormal pellet loading.	Contact after-sales centre

GUARANTEE TERMS

1. Extraflame S.p.A. products are guaranteed, within the European community, for 24 months from the date of purchase. Purchase has to be proved by means of a valid fiscal document issued by the seller (receipt, invoice or shipment document) identifying the purchased product and its purchase and/or delivery date.

WARNING: *This conventional guarantee does not replace the guarantee regulated by the European legislation on consumer rights.*

The conventional guarantee is only applicable to the Italian region and to those areas, within the European Community, where the Authorised Technical Assistance Centres are active (see the www.lanordica-extraflame.com website)

It is also limited to the state of residence of the consumer, which must coincide with the premises and/or registered office of the seller of the Extraflame S.p.A. product

These regulations do not apply if the product is purchased within commercial, entrepreneurial, or professional circumstances. In these cases the product guarantee will be limited to a period of 12 months from the date of purchase.

ITALIAN GUARANTEE

What must be done if there is a product malfunction:

Consult the instructions manual to make sure the malfunction cannot be solved by using the product correctly. Make sure the malfunction is included in those covered by the guarantee; otherwise the cost of the intervention will be borne entirely by the consumer. When requesting the intervention of the Assistance service at the Authorised Assistance Centre, always specify: - type of malfunction - model of the appliance - complete address - phone number

EUROPEAN GUARANTEE

What must be done if there is a product malfunction:

Consult the instructions manual to make sure the malfunction cannot be solved by using the product correctly. Make sure the malfunction is included in those covered by the guarantee; otherwise the cost of the intervention will be borne entirely by the consumer. Request the intervention of the Assistance service or the address of the Authorised Technical Assistance Centre to the seller; always specify: type of malfunction, model of the appliance, complete address and phone number

If the malfunction arises in the first 6 months of the product's life, the consumer has the right to have the product repaired with no expense. From the seventh to the twenty-fourth month, if a malfunction arises, the consumer will bear the cost of the call, while the seller will pay for the manpower and for any spare parts used.

2. If the malfunction is linked to external events and/or conditions such as, including but not limited to, insufficient capacity of the systems; wrong installation and/or maintenance by the personnel which hasn't got the skills prescribed by the laws of the country of residence of the consumer; negligence; inability to use the product and wrong maintenance by the consumer, with respect to what is reported and recommended by the instructions manual of the product, which is part of the sales contract, this guarantee will be void.

Damage to the product that cannot be related to manufacturing defects are also not included in this guarantee. Similarly are excluded defects related to incorrect operation of the flue, according to the legislation in force in the country at the moment of purchase. Other exclusions include all product defects due to carelessness, accidental breakdown, tampering and/or damage during transport (scratches, dents, etc.), interventions carried out by unauthorised personnel and further damage caused by incorrect interventions by the consumer trying to arrange the initial malfunction.

The following consumables are excluded by the guarantee: gaskets, ceramic or tempered glasses, cast iron grilles or coatings, refractory materials (e.g. Nordiker or others), painted, chrome-plated or golden parts, majolica ware, handles, the brazier and its related components. For Idro products the heat exchanger is not covered by the guarantee if a suitable condensation-proof circuit is not set up to ensure a return temperature of the device of at least 55°C. The guarantee excludes all the external components on which the consumer can directly operate during use and/or maintenance or that can be subject to wear and/or rust and stains on steel due to aggressive detergents.

If malfunctions are signalled which are not later confirmed during check by an authorised technician, the cost of the intervention will be borne entirely by the consumer.

3. If it is not possible to restore product conformity by repairing it, the product/component will be replaced, the guarantee expiration date and conditions will remain the same established when the product/component to be replaced has been purchased.

4. Extraflame S.p.A. cannot be held liable for injury or damage which may - either directly or indirectly - be caused to persons, animals and property ensuing from failure to observe all the instructions provided in the relevant instruction manual and the warnings regarding installation, use and maintenance of the product, that can also be downloaded on the website.

5. Interventions for adjusting and/or regulating the product for the type of fuel or other reasons are excluded by the guarantee.

6. If the product is repaired in one of the Authorised Technical Assistance Centres indicated by Extraflame S.p.A. and if the product is replaced, transport will be free of charge. If the technician can repair the product at the user's place of residence and they refuse, transport to the workshop and redelivery will be paid by the consumer.

7. After the 24 months of the guarantee have elapsed any repair intervention cost will be completely borne by the consumer.

8. In the case of disputes the only competent court is that of the Extraflame S.p.A. registered office - (Vicenza-Italy)

ADDITIONAL WARNINGS

- ◆ Only use the fuel recommended by the manufacturer. The product must not be used as an incinerator.
 - ◆ Do not use the product as a ladder or supporting structure.
 - ◆ Do not place laundry on the product to dry it. Any clothes-horse or similar objects must be kept at due distance from the product.
- Danger of fire or damage to the coating.
- ◆ The user is fully liable for any incorrect use of the product. The manufacturer bears no civil or criminal liability for incorrect use.
 - ◆ Unauthorised tampering of any nature or replacement of spare parts of the product with non-original parts may endanger the operator and the manufacturer bears no civil or criminal liability for this.
 - ◆ Large parts of the surface of the product can get very hot (door, handle, glass, smoke outlet pipes, etc.). Please therefore avoid coming into contact with these parts without wearing suitable protective clothing or using appropriate measures, such as heat protective gloves.
 - ◆ DO NOT use the product with the door open or if the glass is broken.
 - ◆ The product must be electrically connected to a system equipped with an operational earthing system.
 - ◆ Turn off the product in the event of a failure or malfunctioning.
 - ◆ Unburned pellets that build up in the burner following each failed start-up must be removed before attempting to start up the product again. Make sure that the burner is clean and correctly positioned before starting it up again.
 - ◆ Do not wash the product with water. Water may penetrate into the unit and cause faults in the electrical insulation. This can cause electric shocks.
 - ◆ Installations not complying with the regulations in force, as well as incorrect use and failure to comply with the maintenance scheduled by the manufacturer, will invalidate the guarantee.

Extraflame®

Riscaldamento a Pellet

Extraflame S.p.A. Via Dell'Artigianato, 12 36030 - MONTECCHIO PRECALCINO (VI) - ITALY
☎ +39.0445.865911 - 📠 +39.0445.865912 - ✉ info@extraflame.it - 🌐 www.lanordica-extraflame.com

MADE IN ITALY
design & production

*TO FIND THE SERVICE CENTRE NEAREST TO YOU
CONTACT YOUR DEALER OR CONSULT
THE SITE WWW.LANORDICA-EXTRAFLAME.COM*

The manufacturer reserves the right to vary the characteristics and the data reported in this pamphlet at any moment and without notice, in order to improve its products.
This manual, therefore, cannot be regarded as a contract towards other parties.